



Your ref: (8) in EP2/H4/S3/15 Pt. 16
Our ref: CSHK/CCW/GU18/2011/001244
Date: 2 August 2011

Environmental Protection Department

28/F Southern Centre
130 Hennessy Road
Wanchai
Hong Kong

By Hand

Attn: Ms. Raymond Lai

Dear Sir,

Contract No. HY/2009/15

Central -Wan Chai Bypass – Tunnel (Causeway Bay Typhoon Shelter Section)

Environmental Permit No.: FEP-04/356/2009 – A Proposal for the Removal of Odorous Sediment and Slime in Causeway Bay Typhoon Shelter (Revision 2)

We refer to your letter ref (8) in EP2/H4/S3/15 Pt. 16 dated 4 April 2011 with respect to our submitted revision. We would like to address your observations as follows:

1. The current phase of removal of odorous sediment has been completed. We will continue our close monitoring and implementation of proper mitigations in future phases.
2. We have applied the deodorant chemical during removal of odorous sediment. From our experience, the deodorant spraying system can be mobilized to enhance coverage of the dredged sediment on barge.
3. Job reference of Wasmate 1501 has been provided in Section 8.0. Past clients included Drainage Service Department and Government Logistics Department. As we have discussed with you on the phone, the 10 second spray approach was based on our on-site experience under the supervision of the Engineer's Representative. The deodorant spraying cycle would be repeated until odour was not detected. Based on our observation, the abovementioned approach is adequate to mitigate the odour generated.
4. Detail of the patrol including route and intervals have been attached in Appendix I.

Yours faithfully,

For and on behalf of

China State Construction Engineering (Hong Kong) Limited

Simon Tang
Contractor's Representative

ST/KY/ew

Encl.

c.c. AECOM - Mr. Peter Poon
CEDD – Mr. Patrick Keung
HyD – Mr. Jones Lai
ETC – Mr. Raymond Dai
IEC – Mr. Simon Lam

Ref.: AACWBIECEM00_0_1629L.11

1 August 2011

By Post and Fax (2566 2192)

China State Construction Engineering (Hong Kong) Ltd.
29/F, China Overseas Building
139 Hennessy Road
Hong Kong

Attention: Mr. K. Y. Leung

Dear Sir,

**Re: Contract No. HY/2009/15
Central – Wan Chai Bypass – Tunnel (Causeway Bay Typhoon Shelter
Section)
A Proposal for the Removal of Odorous Sediment and Slime in Causeway
Bay Typhoon Shelter (Revision 2)**

Reference is made to your submission of the Proposal for the Removal of Odorous Sediment and Slime in Causeway Bay Typhoon Shelter (Revision 2 dated 1 August 2011) to us through E-mail on 1 August 2011 for our review and comment.

Please be informed that we have no further comments on the captioned submission. We write to verify the captioned submission in accordance with Condition 2.18 of FEP-04/356/2009.

Please feel free to contact the undersigned should you have any queries.

Yours sincerely,



David Yeung
Independent Environmental Checker

c.c.	HyD	Mr. Jones Lai	by fax: 2714 5289
	CEDD	Mr. Patrick Keung	by fax: 2577 5040
	AECOM (CWB)	Mr. Peter Poon	by fax: 3529 2829
	AECOM	Mr. Kelvin Cheng	by fax: 2691 2649
	LAM	Mr. Raymond Dai (ETL)	by fax: 2882 3331

Q:\Projects\AACWBIECEM00\Corr\AACWBIECEM00_0_1629L.11.doc



Lam Geotechnics Limited

Ground Investigation & Instrumentation Professionals

華益土力有限公司

Ref : G1001/CS/L403/FEP-04/356/2009
Date : 1 August 2011

China State Construction Engineering (Hong Kong) Ltd.
29/F, China Overseas Building,
139 Hennessy Road, Hong Kong

Attn: Mr. K. Y. Leung

Dear Sir,

Contract No. HY/2009/15
Central- Wan Chi Bypass – Tunnel (Causeway Bay Typhoon Shelter Section)
Proposal for the Removal of Odorous Sediment and Slime in Causeway Bay Typhoon Shelter (Revision 2)

Referring to your submission of the captioned proposal (Revision 2 dated 1 August 2011) received through email on 1 August 2011, we have reviewed your submitted details and hereby certify this submission in accordance with Condition 2.18 of Further Environmental Permit no. FEP-04/356/2009.

Should you have any enquiry, please feel free to contact the undersigned at 2839 5666.

Yours faithfully,

Raymond Dai
Environmental Team Leader

c.c. CEDD
HyD
AECOM CWB
AECOM WDII
ENVIRON

- Mr. Patrick Keung (By Fax)
- Mr. Jones Lai (By Fax)
- Mr. Peter Poon (By Fax)
- Mr. Frankie Fan (By Fax)
- Mr. David Yeung (By Fax)



CONTRACT HY/2009/15

CENTRAL – WAN CHAI BYPASS
TUNNEL (CAUSEWAY BAY TYPHOON SHELTER SECTION)

**A Proposal for the Removal of Odorous Sediment
and Slime in Causeway Bay Typhoon Shelter**

Submission Status: For Approval

Revision	Description	Date
0	1 st Submission	10 January 2011
1	2 nd Submission	21 February 2011
2	3 rd Submission	1 August 2011

Checked by	Kelven Yip		01/08/2011
	Environmental Supervisor	Signature	Date
Approved by:	Daniel Sin		01/08/2011
	Environmental Officer	Signature	Date
Approved by:	Simon Tang		01/08/2011
	Contractor's Representative	Signature	Date

LIST OF CONTENT

- 1.0 Introduction
- 2.0 Handle of Odorous Sediment
- 3.0 Handle of Slime
- 4.0 Mitigation Measures 1: Plant To Be Used
- 5.0 Mitigation Measures 2: Silt Curtain
- 6.0 Mitigation Measures 3: Barrier System
- 7.0 Mitigation Measures 4: Control the Dredging Rate
- 8.0 Mitigation Measures 5: Control the Odour Impact
- 9.0 Daily Monitoring

APPENDICES

- A Figure 1a of FEP-04/356/2009
- B The Odorous Sediment location and Sediment Categorization Plan
- C Technical Details of the Double Silt Curtains
- D Impermeable Barrier System
- E Manual Injection System
- F Product Data Sheet of Wasmate 1501® Odor Reducer
- G Proposal on the 24-hr Turbidity Monitoring System
- H Installation of Silt Screen at Cooling Water Intakes\
- I Proposal on Impact Monitoring for Odour Patrol along the Shorelines of Causeway Bay Typhoon Shelter and Ex-Wan Chai Public Cargo Working Area

1.0 Introduction

The purpose of this proposal is to provide details of environmental mitigation measures to minimize the odour impact during the dredging operation at the south-western corner area of the Causeway Bay Typhoon Shelter (CBTS) as shown in Figure 1a of FEP-04/356/2009 (see Appendix A).

2.0 Handle of Odorous Sediment

Environmental, Transport and works Bureau Technical Circular (Works) (ETWB TCW) No.34/2002 sets out the management framework for dredged sediment disposal for all projects involving the marine disposal of dredged sediments. Sediment quality data of the abovementioned odorous sediment were found available in the Sediment Quality Report (SQR) for Area of CBTS and Ex-PCWA. The odorous sediment was covered by the sediment samples V06-20, V06-21, V06-22, VC-23 & VC-24. The odorous sediment location and the sediment categorization plan are shown in drawing no. CWBT/EPD/020 enclosed in Appendix B. Due to some samples were classified in Category H_f (Type 3), sealed dredged sediment in geosynthetic container need to carry out before disposal to the South Sha Chau.

For non-Type 3 samples, tarpaulin coverage will be provided on the dredged sediments as soon as dredging is completed. No sediments of any types would be stored overnight within the site area.

3.0 Handle of Slime

Pursuant to “Enhancement Package for Existing Odour Sources identified at Causeway Bay Typhoon Shelter” (Annex A of Appendix 15.1) from EIA Report AEIAR-125/2008, an implementation agent will be identified by CEDD to wash the slime attached at existing seawalls with high pressure water.

4.0 Mitigation Measures 1: Plant To Be Used

It is proposed to use a small grab dredger with 6 m³ volume closed grab to carry out the dredging of odorous sediment, for other dredging works normally adopted closed grab of 8 m³

volume. The grab to be used shall be a closed grab type to prevent the leakage of the dredged material during the lifting and swinging before the discharge of the dredged material into the hopper barge. The hopper barge shall be towed by tug boat to the designated dumping ground for disposal.

5.0 Mitigation Measures 2: Silt Curtain

A frame mounted on the dredger barge will be constructed with double silt curtains which is made of geotextile materials. The toe of the curtain will be lowered simultaneously with the increase of dredging depth so as to prevent migration of sediment plume out of the silt curtain. A sufficient clearance between the toe of the silt curtain and the seabed is maintained in order to prevent the disturbance to the seabed due to the underwater current. Steel chain would be attached to the bottom to maintain the curtains at an upright position. Detail drawing of the double silt curtains for the odorous sediment is shown in Appendix C.

Proper regular maintenance will be carried out for the silt curtain, refuse or debris around the silt curtain would be collected on daily basis to avoid adverse effect to marine plants as well as to the public.

Spare geotextile materials and other associated components will be stored on site for readily repairing/replacement in case of damages.

6.0 Mitigation Measures 3: Barrier System

An impermeable barrier system which is made of PE waterproof tarpaulin, to isolate the odorous sediment removal works area, suspended from a floating boom on the water surface and extended down to the seabed. Detail drawing and the specimen of an impermeable barrier are shown in Appendix D.

7.0 Mitigation Measures 4: Control the Dredging Rate

The rate of dredging works has been strictly governed by the conditions stated in the FEP-04/356/2009, i.e. 6,000m³ per day (i.e. 375m³ per hour).

8.0 Mitigation Measures 5: Control the Odour Impact

CSHK appointed Air & Water Purification Equipment Co. Ltd to formulate by addition of De odorant liquid on the odour generating sediment. Details of the work as below:

1. A de odorant liquid call **Wasmate 1501® Odor Reducer** will be continuously injected to the dredged sediments during the dredging and handling of the contaminated sediments. Manual injection system is shown in Appendix E and product data sheet of **Wasmate 1501® Odor Reducer** is shown in Appendix F;
2. Manual Dose machine consists of 2 set of 200 litre chemicals storage tanks, 2 set electric mist pump and 2 set hand held spray gun for mist disposal on top of the sediments;
3. An operator to dose and control the spray unit. The objective of the worker is the spray the de odorant liquid on top of the sediment in proportion of 1,000 litre of sediment with 3 litre of de odorant liquid;
4. Products Warranty — **Wasmate 1501® Odor Reducer** is being used in the local Government project for more than 3 years. The product provided in this project (**Wasmate 1501® Odor Reducer**) will be sample by Accredited Laboratory to proceed a H₂S reduction performance test to make sure it can reduce H₂S at least 90%. One 2 litre-sample will be collected when goods delivery to site and send back to nominated laboratory for performance test. The test will be done on a 128 chamber, fill up with 23-28 ppm H₂S gas, inject 25ml-35ml **Wasmate 1501® Odor Reducer** by mist pump inside the chamber and take sample for H₂S content for confirming the reduction efficient is greater than 90 %;
5. Based on previous on-site experience, for every grab of sediments De odorant will be sprayed for 10 seconds onto the surface of the dredged sediments. The De odorant spraying cycle shall be continued for the dredged sediments until odor is not detected.
6. Supplier of De odorant, CSHK and de odorant spray system operator will provide contact cellular at all times to make sure the work is work according to the schedule.

Job references of **Wasmate 1501® Odor Reducer** are as follows:

Client: Drainage Service Department

Tender Reference No.: D0010942009

Contract No.: C0004/2010

Date: 13 April 2010 to 15 August 2011

Supply: 50,000 litre

Contract No. HY/2009/15

Central -Wan Chai Bypass – Tunnel (Causeway Bay Typhoon Shelter Section)

Client: Government Logistics Department

Tender Reference No.: D0010082008

Contract No.: C0099/2008

Date: 4 August 2008

Supply: 50,000 litre

9.0 Daily Monitoring

The daily monitoring of suspended solids at the cooling water intakes will be carried out by Lam Geotechnics Limited, the Environmental Team (ET) that appointed by Highway Department and the result will report in the monthly EM&A report. 24-hour monitoring of turbidity at intake(s) which is in operation will be implemented during the dredging activities. A diagram showing the locations of the cooling water intake is provided in Figure 1 of Appendix G. Silt screens have been installed at the intakes (see Appendix H).

Pursuant to Table A13.1 of Appendix A of Updated EM&A Manual for EP-356/2009, an implementation agent has been identified by CEDD to carry out odour patrol during dredging in the construction phase. Detail of the patrol including route and intervals have been attached in Appendix I.

Appendix A – Figure 1a of FEP-04/356/2009

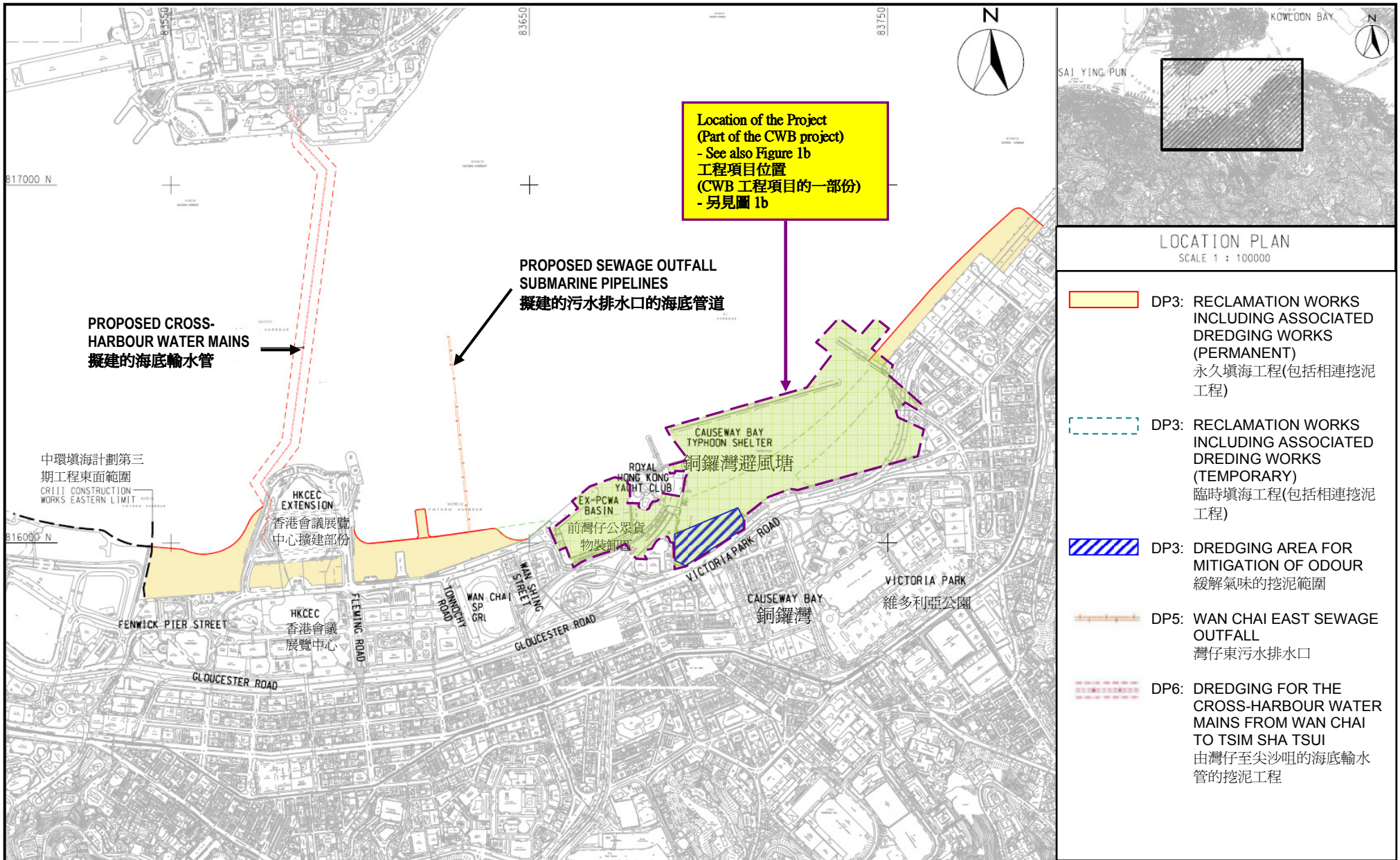

Project Title: Central - Wan Chai Bypass - Tunnel (Causeway Bay Typhoon Shelter Section)
 (Contract No. HY/2009/15) - Marine Works
工程項目名稱: 中環灣仔繞道- 隧道工程(銅鑼灣避風塘段)(合約編號: HY/2009/15) - 海事工程











Environmental Permit No. : FEP- 04-356/2009
環境許可證編號 : FEP-04-356/2009

Figure 1a : Location of the Project
圖 1a : 工程項目位置







(This figure was prepared based on Figure 1 of Application for Further Environmental Permit (Application No.: FEP-117/2010))
 (本圖是根據申請新的環境許可證(申請書編號 FEP-117/2010)圖 1 編製)

Appendix B – The Odorous Sediment Location and The Sediment Categorization Plan

LEGEND:

-  VC 26 MARINE SEDIMENT SAMPLING LOCATION UNDER CURRENT SA3
-  V06-28 VIBROCORE FOR MARINE SEDIMENT SAMPLING UNDER WAN CHAI DEVELOPMENT PHASE II - PLANNING & ENGINEERING REVIEW, EIA 2007
-  VC 48 VIBROCORE FOR MARINE SEDIMENT SAMPLING UNDER AGREEMENT NO. CE54/2001(CE) WAN CHAI DEVELOPMENT PHASE II DESIGN & CONSTRUCTION, 2003
-  S101 SETTING OUT POINT
-  TYPE 1 - OPEN SEA DISPOSAL (CATEGORY L SEDIMENT)
-  TYPE 1 - OPEN SEA DISPOSAL (DEDICATED SITES) (CATEGORY M SEDIMENT)
-  TYPE 2 - CONFINED MARINE DISPOSAL (CATEGORY M SEDIMENT)
-  TYPE 2 - CONFINED MARINE DISPOSAL (CATEGORY H SEDIMENT)
-  TYPE 3 - SPECIAL TREATMENT/DISPOSAL (CATEGORY H SEDIMENT)
-  ODOROUS SEDIMENT

KEY:

-  V06-18a ← VIBROCORE NUMBER
-  ← EXISTING SEABED LEVEL
-  ← TYPE AND CATEGORY OF SEDIMENT (SEE ABOVE)
-  0.9 ← DEPTH IN m BELOW SEABED
-  1.9 ←
-  2.9 ←
-  3.9 ←

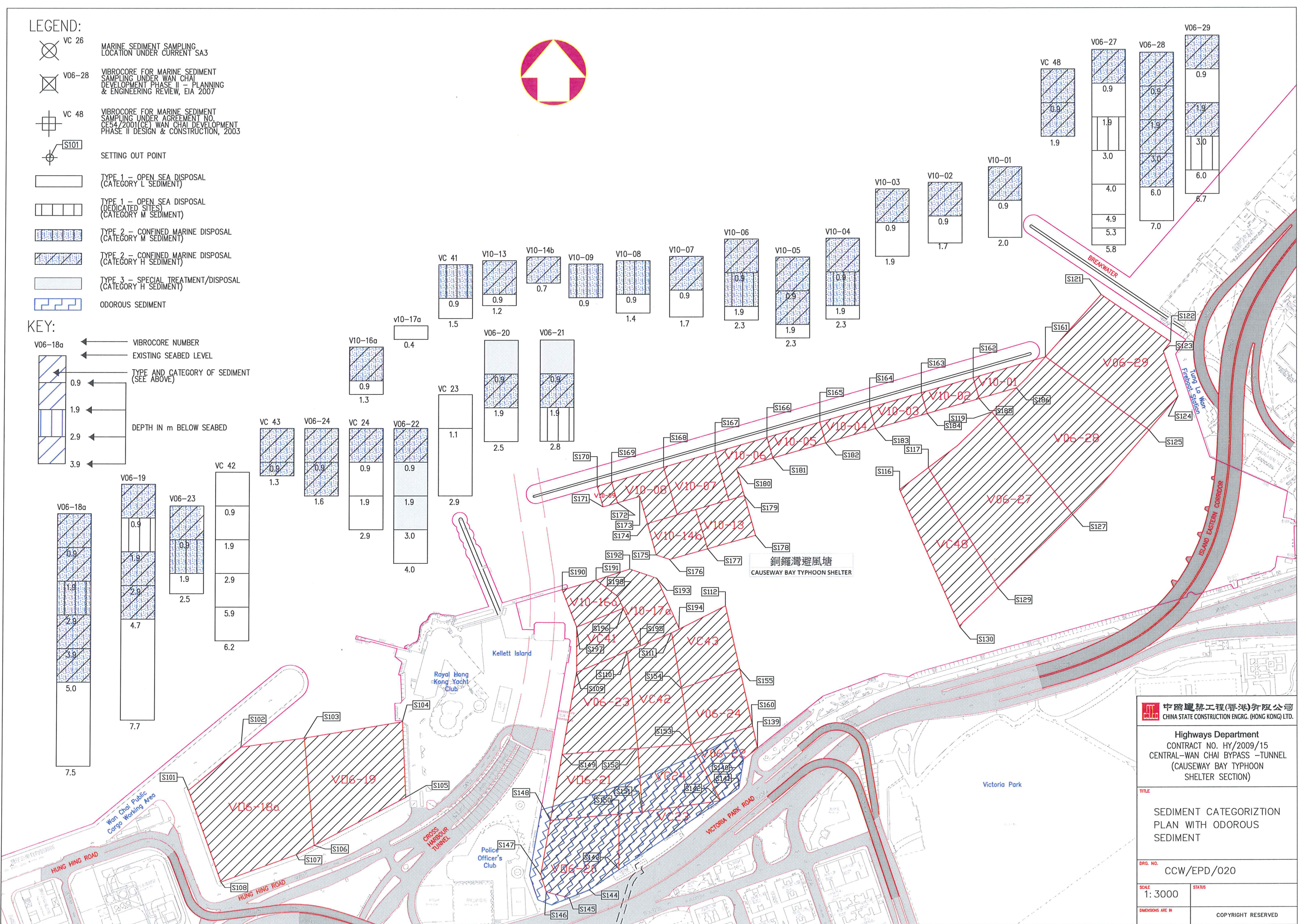
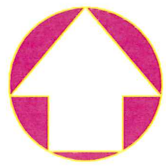

 中國建築工程(香港)有限公司 CHINA STATE CONSTRUCTION ENGRG. (HONG KONG) LTD.	
Highways Department CONTRACT NO. HY/2009/15 CENTRAL-WAN CHAI BYPASS -TUNNEL (CAUSEWAY BAY TYPHOON SHELTER SECTION)	
TITLE	
SEDIMENT CATEGORIZATION PLAN WITH ODOROUS SEDIMENT	
DRG. NO.	
CCW/EPD/020	
SCALE	STATUS
1: 3000	
DIMENSIONS ARE IN	
COPYRIGHT RESERVED	

Contract No. HY/2009/15

Central -Wan Chai Bypass – Tunnel (Causeway Bay Typhoon Shelter Section)

Appendix C – Technical Details of the Double Silt Curtains

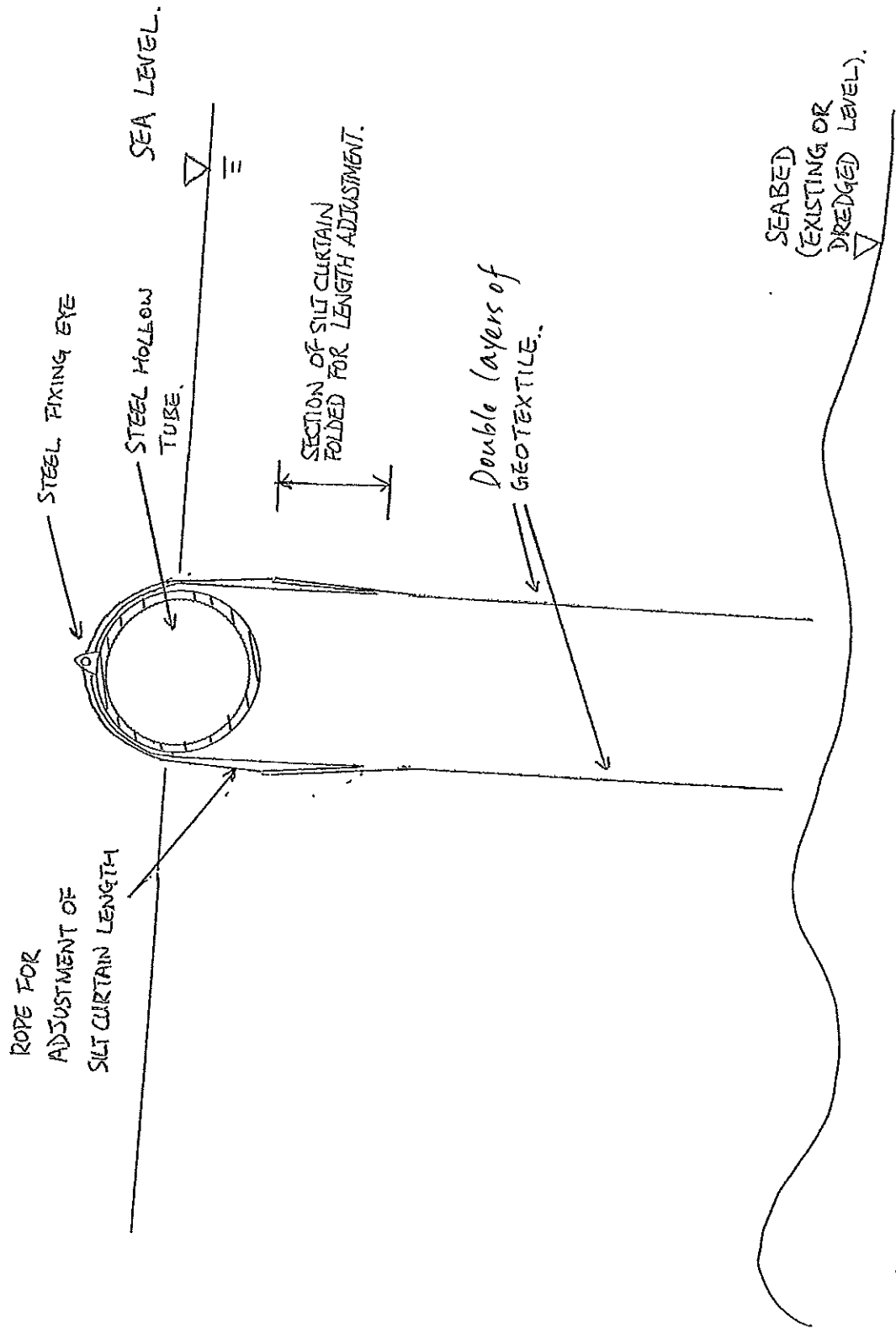

DRAWING NOT TO SCALE

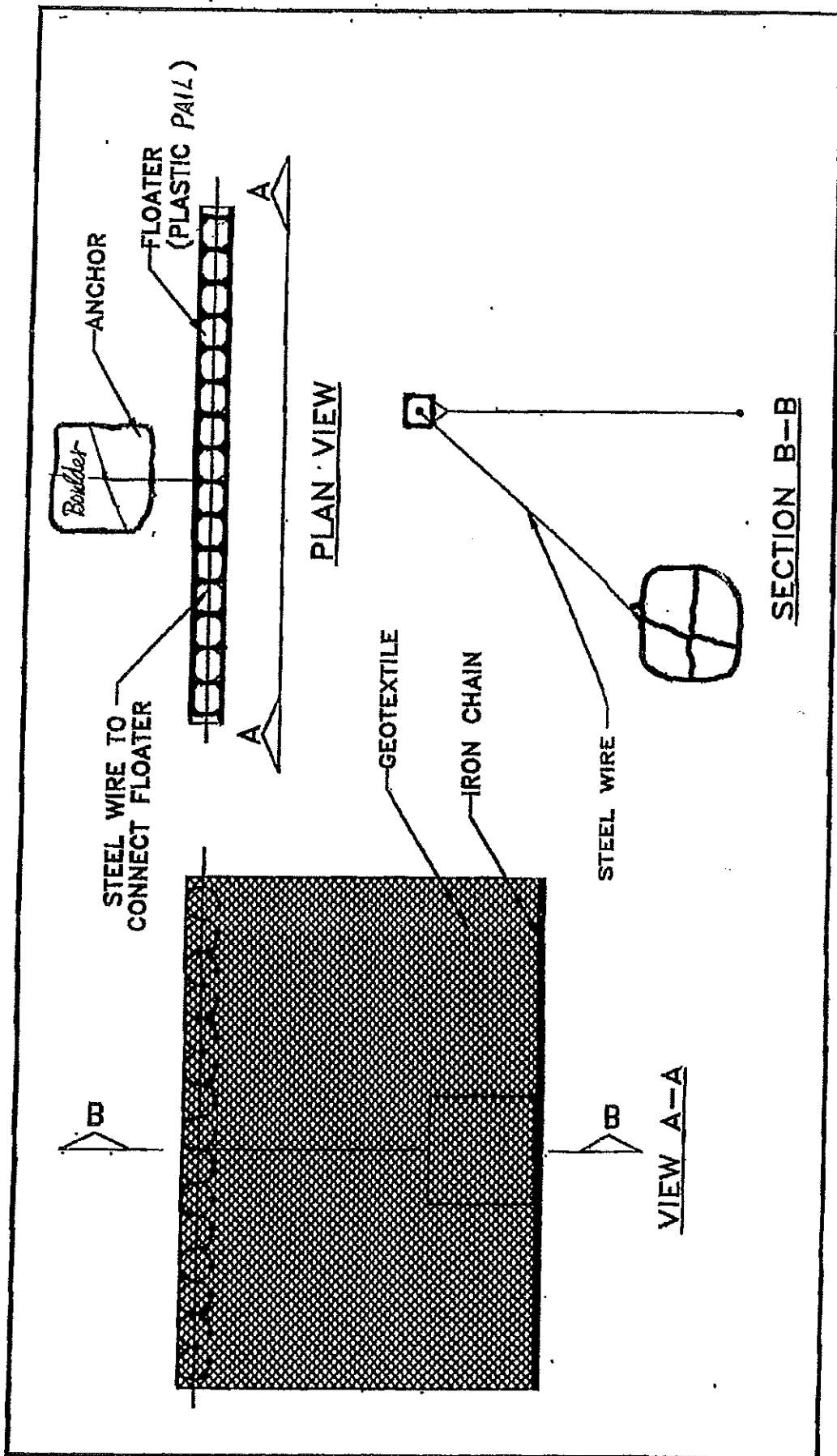

DETAILS OF DOUBLE SILT CURTAIN

Contract No. : HY/2009/15
Central - Wan Chai Bypass - Tunnel
(Causeway Bay Typhoon Shelter Section)

Details of Silt Curtain Arrangement (Applicable for Dredging in CBTS only)

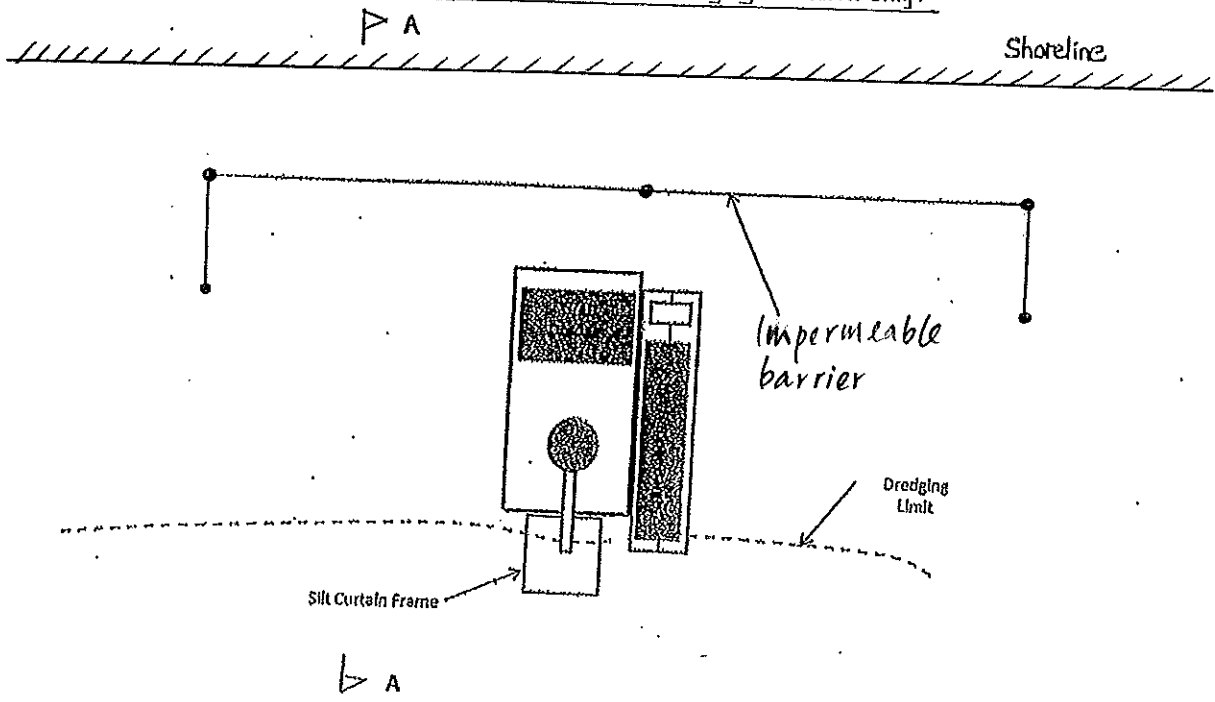

PLAN

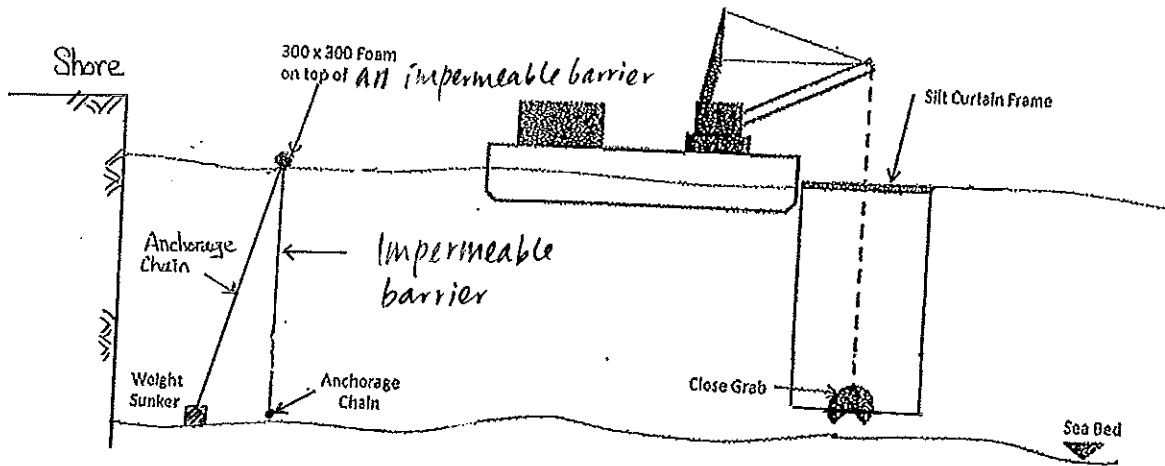

SECTION A-A

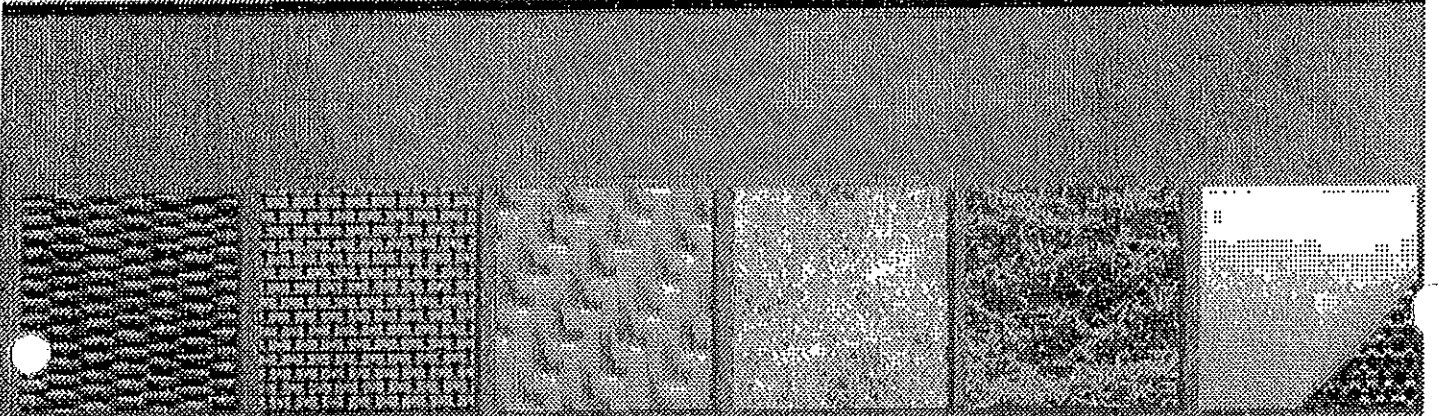
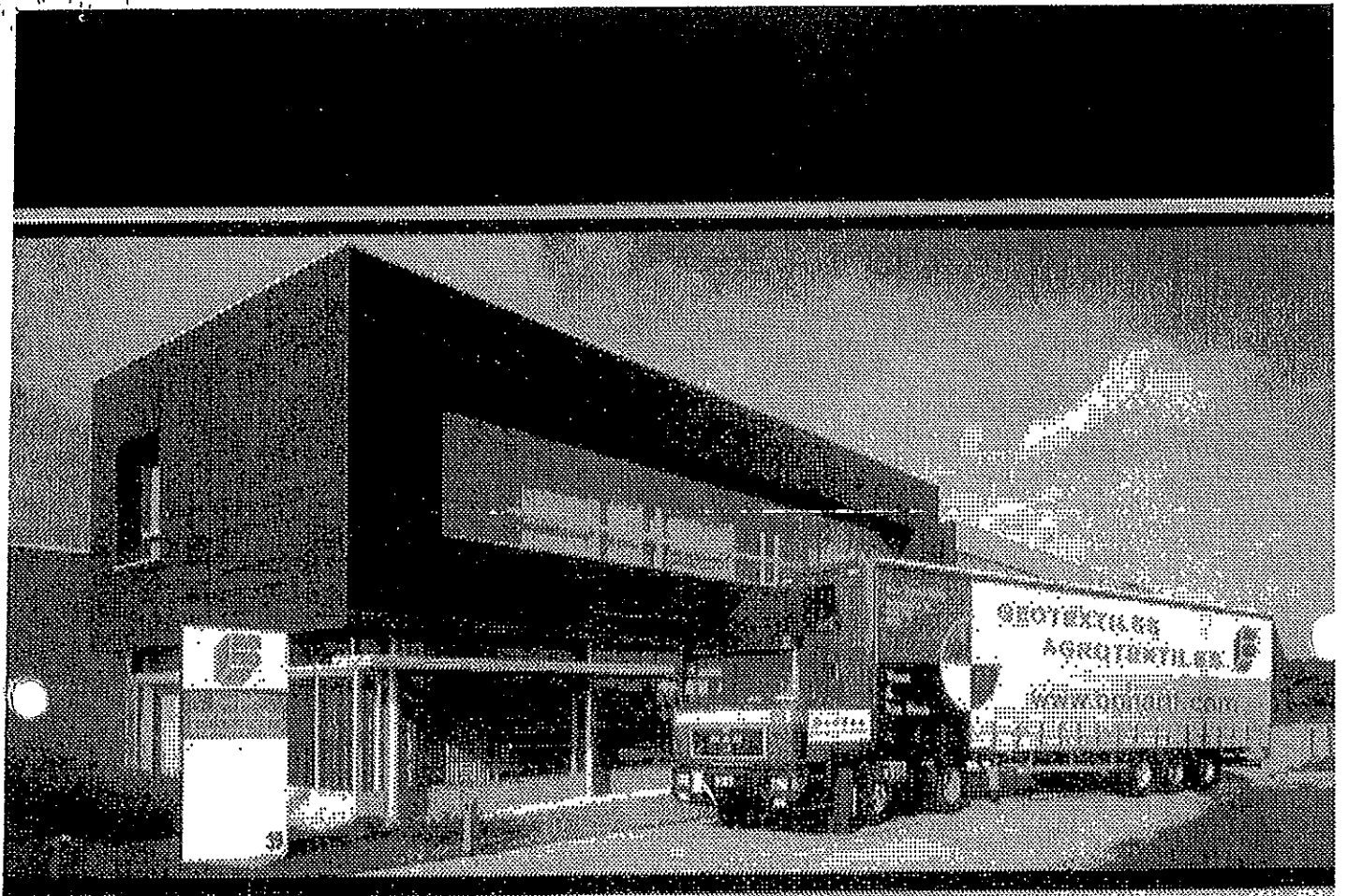

WE UNDERCOVER THE WORLD

bontec
woven and nonwoven geotextiles

A TOTAL RANGE OF GEOTEXTILES

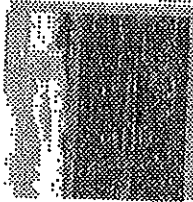
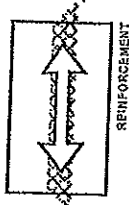
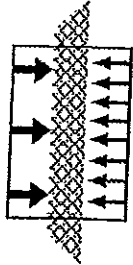
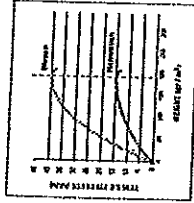
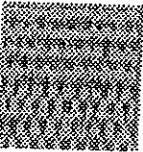

Other geotextile applications include: Slope stabilization, Roadway construction, Landfill liner, High-strength woven and knitted geotextiles, and High-strength woven and knitted geotextiles.

*An existing range of Standard Grade geotextiles has offer the perfect solution to your application requirements. With tensile strengths ranging from 10 to 200 kN/m you can be certain that an SS fabric will be available with the performance that you are looking for.

DAILY SEPARATION, SOIL STRENGTHENING OR GROUND REINFORCEMENT

Entire SS woven geotextiles are manufactured from polypropylene fibres & yarns, and exhibit an excellent chemical resistance to commonly encountered acids and alkalis at ambient temperatures. Available in a lightweight range with products from 10 to 200 kN/m, and a heavyweight range from 200 to 600 kN/m.

Secure SS have available:

- 3) Tensile strengths up to 300 kN per metre (kN/m) width
- 4) CSR Protective Strengths ranging from 1,200 N to 12,500 N
- 5) Mechanical Properties that offer maximum strength at minimal cost and ensure the products availability both against installation damage and in the longer term.
- 6) Lightweight woven products that offer greater mechanical strengths per unit weight than comparable nonwoven grades. This makes lightweight woven geotextiles the ideal choice for some applications that require by design.

- 7) A range of consistent opening sizes suitable for use in soils ranging from clay to coarse granular fill
- 8) SS hydraulic properties that are suited to the demands of everyday separators.

- 9) Available in stock in 4.5m and 6.25m wide rolls or other widths to order
- 10) Typical applications for SS woven geotextiles include:

- As a trench or surface separator for use under site access roads and areas of hardstanding.
- As a separation and strengthening layer under new roadways, car parks, industrial units etc.
- As an erosion control layer under new or rock armor in coastal defence projects.
- For any separation application where there exists a need to prevent the intermingling of such materials such as geotextiles.

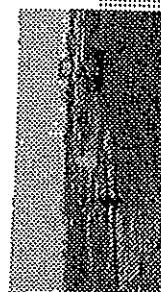

Other geotextile applications include: Slope stabilization, Roadway construction, Landfill liner, High-strength woven and knitted geotextiles, and High-strength woven and knitted geotextiles.

Other geotextile applications include: Slope stabilization, Roadway construction, Landfill liner, High-strength woven and knitted geotextiles, and High-strength woven and knitted geotextiles.

SS WOVEN GEOTEXTILES

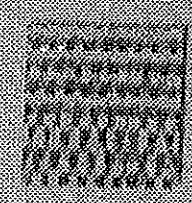



G AND E COMPANY LIMITED

Room B, 13/F Cheung Lee Industrial Bldg.
9 Cheung Lee Street
Chai Wan, Hong Kong
Tel: 2508 0058

Fax: 2570 0089

website: www.g-and-e.com

July 9, 2010

OFFICIAL ANNOUNCEMENT

I would like to inform you that geotextile Bontec SG100/100 is upgraded to SG110/110 effective immediately, and that SG100/100 has become obsolete. The performance of SG110/110 is superior to that of SG100/100.

No adjustment and adaptation are necessary to the current application, installation method, packaging and quality control assurance program with the improved properties of SG110/110.

Bonar Technical Fabrics is Europe's premier manufacturer of woven and non-woven geotextile products, with continuous commitment to quality, product development and production improvement. One of Bonar's many advantages is that they are vertically integrated. This means they have their own fiber production which helps ensure consistent product performance. Bonar also has a high production capacity with the facility located in close proximity to the Antwerp port. These translate into more efficient supply.

I have attached the manufacturer's letter here about the change for your reference. We would be happy to answer any questions that you may have.

Thank you for your kind attention.

Best regards

Gary Ng

Gary Ng
General Manager

bontec

a bonar technical fabrics product

Date: 5-Jul-10

To: G and E – Hong Kong
Gary

From: Isabelle Ruyffelaere – 0032 52 457 487

Philippe Grimmelprez – 0032 52 457 486

E mail: nannette@g-and-e.com

Pages: 1 +

Your reference: Bontec® SG 110/110

Our reference: G&E07052010.doc

Dear Gary,

We are pleased to confirm that the old name of the Bontec® SG100/100 has been replaced with the Bontec® SG 110/110.

Bonar constantly strives to increase the performance of the products over time. Thanks to improved polymers, extrusion and weaving techniques we managed to produce stronger geotextiles with the same unit weight. Hydraulic characteristics were not affected either.

Bonar uses very strict -in house- and ISO 9001:2000 quality and ISO 14001 environmental standards (in annex) and is using electricity generated from 100 % renewable sources.

We send hereby the newest datasheet as well for your information.

Should you require any further information, please do not hesitate to contact us.

Best regards

Philippe Grimmelprez
Global Sales & Marketing Manager



BONAR Technical Fabrics nv/na
Industrieweg 28 • B-2314 Zate • Belgium
Tel. +32 (0)52 457 487 • Fax. +32 (0)52 457 486
E-mail: info@bonar.com

BONAR Nylon & Polyester Ltd.
St. James Street • London E8 3JY • United Kingdom
Tel. +44 (0)202 941192 • Fax. +44 (0)202 941193
E-mail: info@bonar.com

bontec

a bonar technical fabrics product

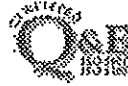

SG 110/110

Woven polypropylene geotextile made of slit film tapes

Technical data sheet according to internal specifications Bonar TF: version 06 dd. 05/01/10
Accompanying documents CE marking: version 04 dd. 05/01/10



1137-CPD-615

10

separation	filtration	reinforcement	protection	drainage

	test method	value	tolerance
Mechanical properties			
Tensile strength MD		110,0 kN/m	-9,9 kN/m
Tensile strength CD	EN ISO 10319	110,0 kN/m	-9,9 kN/m
Elongation MD		12,0 %	+/-2,8 %
Elongation CD	EN ISO 10319	8,0 %	+/-1,8 %
Static puncture resistance – CBR	EN ISO 12236	12,50 kN	-2,50 kN
Dynamic perforation resistance – cone drop	EN ISO 13433	10,0 mm	+2,0 mm
Hydraulic properties			
Water permeability normal to the plane		25x10 ⁻³ m/s	-8x10 ⁻³ m/s
Water flow normal to the plane (*)	EN ISO 11058	25 l/m ² .s	-8 l/m ² .s
Characteristic opening size (AOS)	EN ISO 12956	230,0 µm	+/-69,0 µm
Physical properties			
Thickness under 2 kPa (*)	EN ISO 9863-1	1,53 mm	+/-0,31 mm
Weight (*)	EN ISO 9864	464,0 g/m ²	+/-46,4 g/m ²
Composition	100 % polypropylene woven geotextile		
Durability	predicted to be durable for a minimum of 25 years in natural soil with 4 < pH < 9 and soil temperatures < 25° C		

roads	railways	foundations & retaining walls	drainage systems	erosion control systems
EN 13249:2000	EN 13250:2000	EN 13251:2000	EN 13262:2000	EN 13263:2000
reservoirs & dams	canals	Tunnels & underground structures	solid waste	liquid waste
EN 13254:2000	EN 13266:2000	EN 13266:2000	EN 13267:2000	EN 13266:2000

1. This geotextile is intended for use in both functions & applications highlighted with a bold border.
 2. It is the responsibility of all users to satisfy themselves that the above data is current.
 3. Roll dimensions are 5,25 m x 100 m. Other dimensions on demand.
 4. Bonar Technical Fabrics reserves the right to alter product specifications without prior notice.
 5. Although not guaranteed, these results do to the best of our knowledge offer a true and accurate record of the product's performance.
 6. Bonar Technical Fabrics cannot accept responsibility for the performance of these products as the conditions of use are beyond our control.
 7. Geotextile has to be covered within 2 weeks after installation.
- (*) Not mandated characteristics for CE marking.



BONAR Technical Fabrics nv/sa, Industriestraat 39, 9240 Zelo, BELGIUM - ☎ +32(0)52 457411 - 📠 +32(0)52 457495
BONAR Yarns & Fabrics Ltd, St. Salvador Street, Dundee DD3 7EU, UK - ☎ +44(0)1382 346102 - 📠 +44(0)1382 202378

Bonar

Date	Project	Client	Consultant	Style
Feb-05	CV/2003/06 Stanley Waterfront Improvement Project - Construction Pier and Boardwalk	Sun Fook Kong (Civil) Ltd	Civil Engineering and Development Department	SG100/100 NW10
Feb-05	99/9028 Lamma Power Station	Wai Kee (Zens) Construction & Transportation Co Ltd	Maunsell Geotechnical Services Ltd	SG100/100
Feb-05	CV/2004/02 Reconst. of Wong Shek & Ko Lau Wan Public Piers	Kin Shing Construction Co Ltd	Civil Engineering and Development Department	SG100/100
Apr-05	CV/2002/04 Penny's Bay Reclamation Stage 2	Gammon Skanska Ltd Shun Tat Construction Engineering Ltd	Scott Wilson Ltd	SG100/100 SG100/100
Apr-05	HK/12/02 CED, Central Reclamation Phase III, Engineering Works	Best Leader Engineering Ltd Leighton - China State - Van Oord Joint Venture	Atkins China Ltd	SG100/100 SG100/100
May-05	03/8013 Lamma Island to Cyberport	Leader Marine Contractors Ltd Honwin Engineering Ltd	Maunsell Geotechnical Services Ltd	SG100/100 SG100/100
Jul-05	Shenzhen to Tai Po Twin Submarine Gas Pipeline Project	Honwin Engineering Ltd		SG100/100
Sep-05	TP37/03 Remaining Engineering Infrastructure Works for Pak Shek Kok Development Package 2A	Leader - Wai Kee (C&T) Joint Venture	Hyder Consulting Ltd	SG100/100
Nov-05	HY/2002/26 Stone Cutter's Bridge	Hong Kong River Engineering Co Ltd	Ove Arup & Partners HK Ltd	SG100/100
Feb-06	CV/2005/12 Fill Reception Facilities at Tseung Kwan O Area 137 Quarry Bay and Mui Wo	Penta-Ocean Construction Co Ltd	Civil Engineering and Development Department	SG100/100
Mar-06	Maintenance Dredging at Castle Peak Power Station (CPPS) Jetty	New Concepts Engineering Development Ltd	Civil Engineering and Development Department	SG100/100
Mar-06	CV/2004/04 Maintenance and Repairs to Government / Public Piers and Immersed Tubes of Hung Hom Cross- Harbor Tunnel	China Harbour Engineering Co (Group)	Civil Engineering and Development Department	SG100/100
Mar-06	HY/2005/06 Castle Peak Road Improvement West of Tsing Lung Tau	Shun Tat Construction Engineering Limited Chun Wo Construction & Engineering Co Ltd	Mouchel Halcrow JV	SG100/100 SG100/100

May-06	212 Main Works for the Proposed Third Golf Course Development at Kau Sai Chau, Sai Kung	China Harbour Engineering Co (Group)	Ove Arup & Partners HK Ltd	SG100/100
Jun-06	Hong Kong Convention and Exhibition Centre Project - Silt Screening for Intake Pipe	Wai Kee (Zens) Construction & Transportation Co Ltd Kaden - Wai Kee (C&T) Joint Venture	NA	SG100/100 SG100/100
Aug-06	EP/SP/52/06 Development of EcoPark in Tuen Mun Area 38	Kaden Construction Limited	Scott Wilson Ltd	SG100/100
Sep-06	CV/2004/06 Management and Capping of Contaminated Mud Pit IV at East of Sha Chau - Phase III	Kaden - Wai Kee (C&T) Joint Venture	Civil Engineering and Development Department	SG100/100
Oct-06	Lamma Island Cable Landing	United Marine Co Ltd	Hong Kong Electric Co Ltd	SG100/100
Nov-06	CV/2004/01 Maintenance and Repairs to Seawalls, Piers and Other Port Works	Kin Shing Construction Co Ltd	Civil Engineering and Development Department	SG100/100
Dec-06	Private project	Friendly Benefit Engineering Ltd		SG100/100
Feb-07	Prebored Socketted H-Piles at Hong Kong Convention & Exhibition Centre	Yee Hop Engineering Co Ltd	NA	SG100/100
May-07	HY/2005/06 Castle Peak Road Improvement - West of Tsing Lung Tau	Chun Wo Construction & Engineering Co Ltd	Mouchel Halcrow JV	SG100/100
May-07	CV/2004/05 Dredging Maintenance	China Harbour Engineering Co Ltd	Civil Engineering and Development Department	SG100/100
Aug-07	Dredging Project in Lai Chi Kok Shipyard	Maritime Mechanic Ltd	NA	SG100/100
Aug-07	6/WSD/06 Construction of Salt Water Supply System for Penny's Bay	Univic Engineering Ltd	Water Supplies Department	SG100/100
Nov-07	Permanent Aviation Fuel Facility Hong Kong International Airport (Contract No. H2104)	UDL Dredging Ltd	Babtie Asia Ltd	SG100/100
Dec-07	Seawall Modify, Tuen Mun Area 38	Cheer Engineering Ltd	Scott Wilson Ltd	SG100/100
May-08	DC/2007/10 Design and Construction of HK West Drainage Tunnel	Tapco Civil Engineering Co Ltd	Ove Arup & Partners HK Ltd	SG100/100
Sep-08	CV/2006/05 Maintenance of Seawalls and Navigation Channels	China Harbour Engineering Co Ltd	Civil Engineering and Development Department	SG100/100



G AND E COMPANY LIMITED

Room B, 13/F Cheung Lee Industrial Building
9 Cheung Lee Street,
Chai Wan, Hong Kong
Tel: 852-2508 0058 Fax: 852-2570 0089
website: www.g-and-e.com

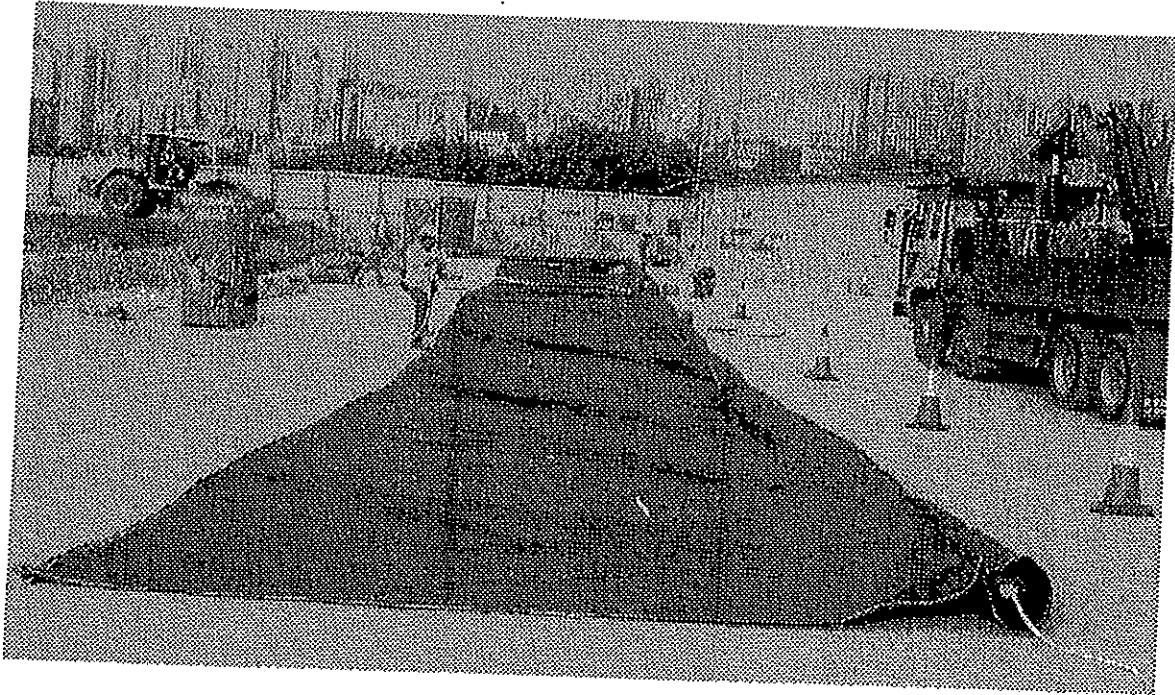

Date	Mar 2010
Project	Contract No. KL/2009/01 Site formation for Kai Tak Cruise Terminal Development
Client	CEDD
Consultant	Scott Wilson Ltd
Main Contractor	Penta-Ocean Construction Co. Ltd
Works	SG100/100 as Silt Curtain
Size	1,050 sq m



G AND E COMPANY LIMITED

Room B, 13/F Cheung Lee Industrial Building

9 Cheung Lee Street,

Chai Wan, Hong Kong

Tel: 852-2508 0058 Fax: 852-2570 0089

website: www.g-and-e.com

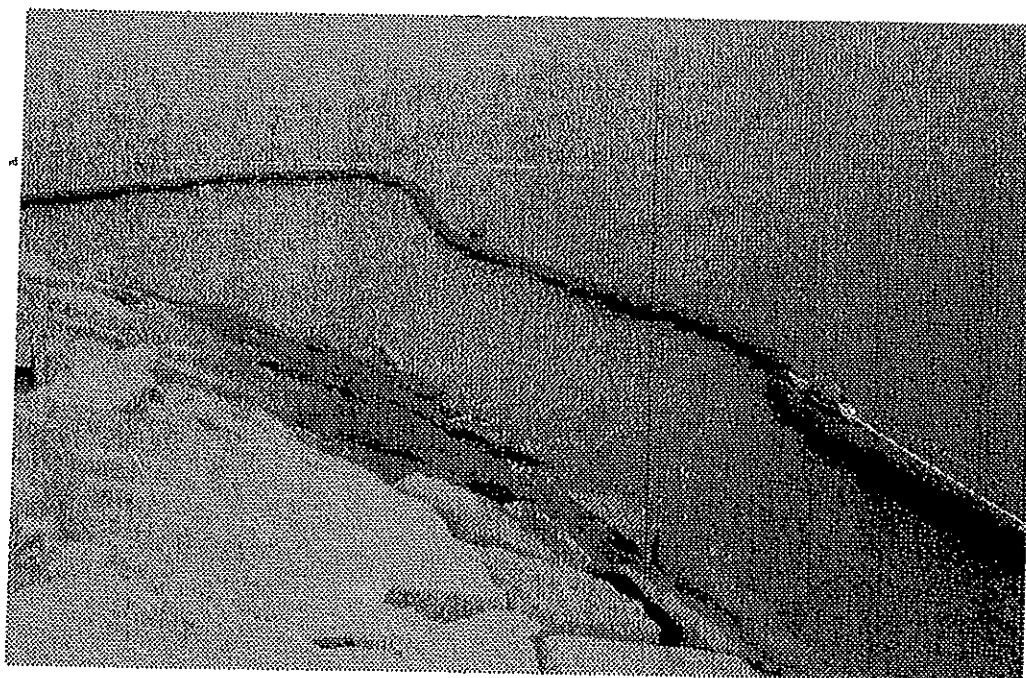

Date	March 2010
Project	KL/2009/01 Site formation for Kai Tak Cruise Terminal Development
Client	CEDD
Consultant	Scott Wilson Ltd
Main Contractor	Penta-Ocean Construction Co. Ltd
Materials	SG100/100
Size	1,050 sqm

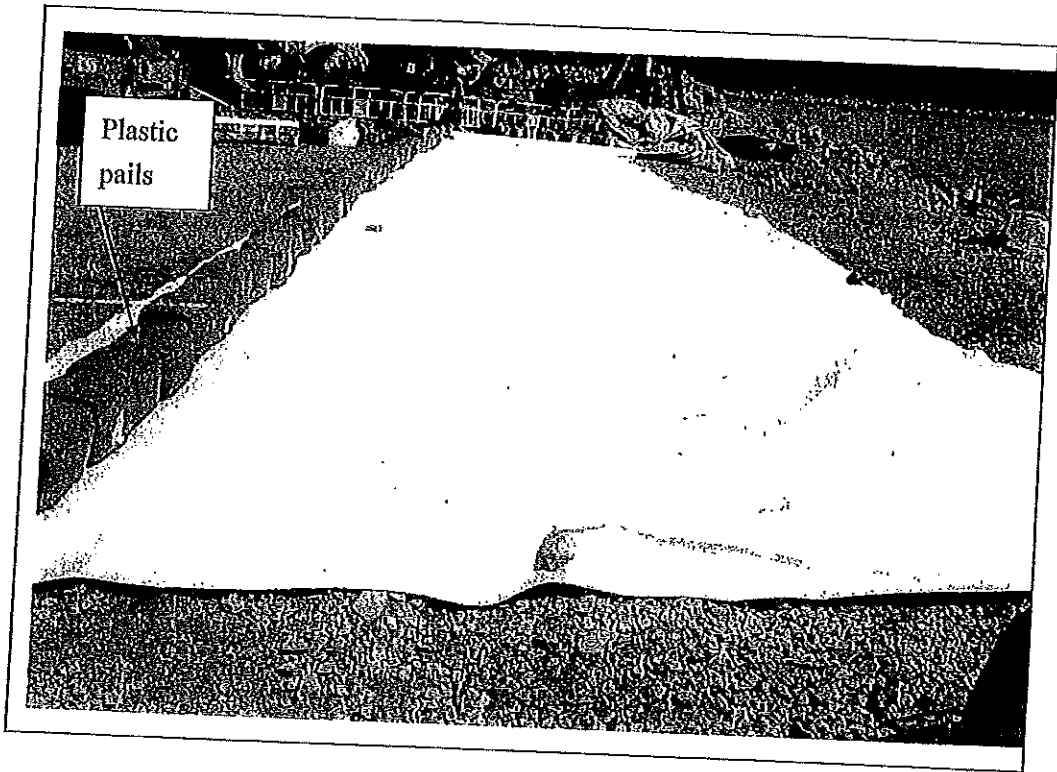

Photo shown Geotextile and Plastic Pails

Appendix D –Impermeable Barrier System

Contract No. HY/2009/15

Central -Wan Chai Bypass – Tunnel (Causeway Bay Typhoon Shelter Section)



Impermeable Barrier

IMPERMEABLE BARRIER EXTENDED DOWN TO SEABED TO ISOLATE THE ODOROUS SEDIMENTS

PORTION FOR REMOVAL OF ODOROUS SEDIMENT

-4.3 mPD

DOUBLE LAYER SILT CURTAINS FOR DREDGING AREA DURING THE DREDGING OPERATION

CSCEC 中國建築工程(香港)有限公司
CHINA STATE CONSTRUCTION ENGRG. (HONG KONG) LTD.

Highway Department
CONTRACT NO. HY/2009/15
CENTRAL-WAN CHAI BYPASS -TUNNEL
(CAUSEWAY BAY TYPHOON SHELTER SECTION)

TITLE
DETAILS OF IMPERMEABLE BARRIER AND SILT CURTAIN ARRANGEMENT FOR ODOROUS SEDIMENT

DRG. NO. CCW/EPD/021

SCALE
1:500 @ A3

DIMENSIONS ARE IN METRES

STATUS
COPYRIGHT RESERVED

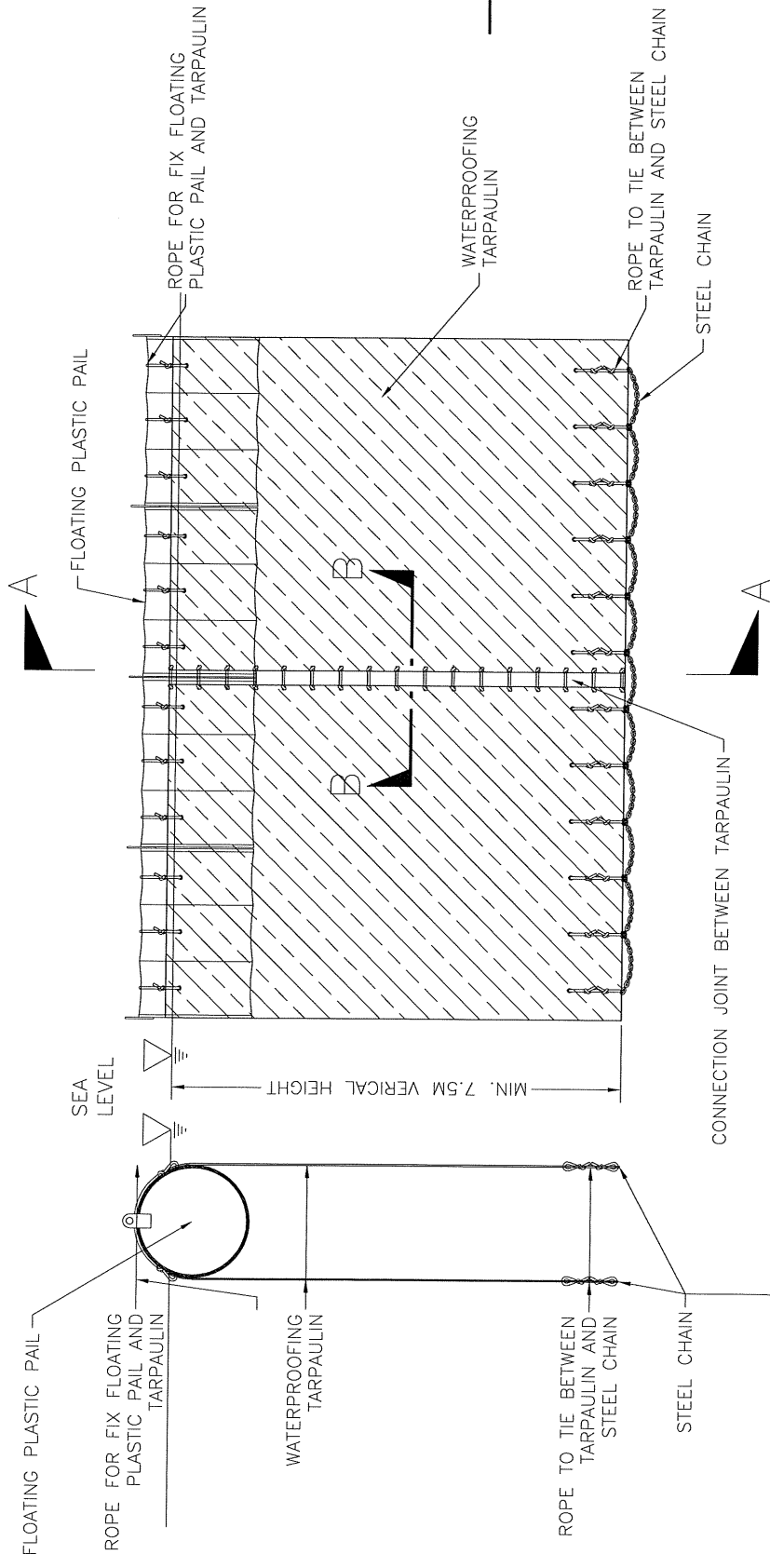

SECTION B-B
NOT TO SCALE

SECTION A-A ELEVATION FOR WATERPROOF BARRIER

Highways Department 路政署
Major Works Project Management Office

CONTRACT NO. HY/2009/15
CENTRAL-WAN CHAI BYPASS - TUNNEL
(CAUSEWAY BAY TYPHOON SHELTER SECTION)

ELEVATION AND SECTION FOR WATERPROOF BARRIER OF MITIGATION OF ODOUR DURING BREDDING WORKS

中環運務工程(避風)有限公司
CHINA STATE CONSTRUCTION ENGINEERING LTD.

DRG. NO.	CCW/SK/004
SCALE	1:500
DESIGNED BY	AW
FOR APPROVAL	
COPYRIGHT RESERVED	

Contract No. HY/2009/15

Central -Wan Chai Bypass – Tunnel (Causeway Bay Typhoon Shelter Section)

Appendix E – Manual Injection System

CHEMICAL TANK
 PUMP & SPRAY GUN. FOR
 DEODOR LIQUID FOR
 SLURRY ODOR

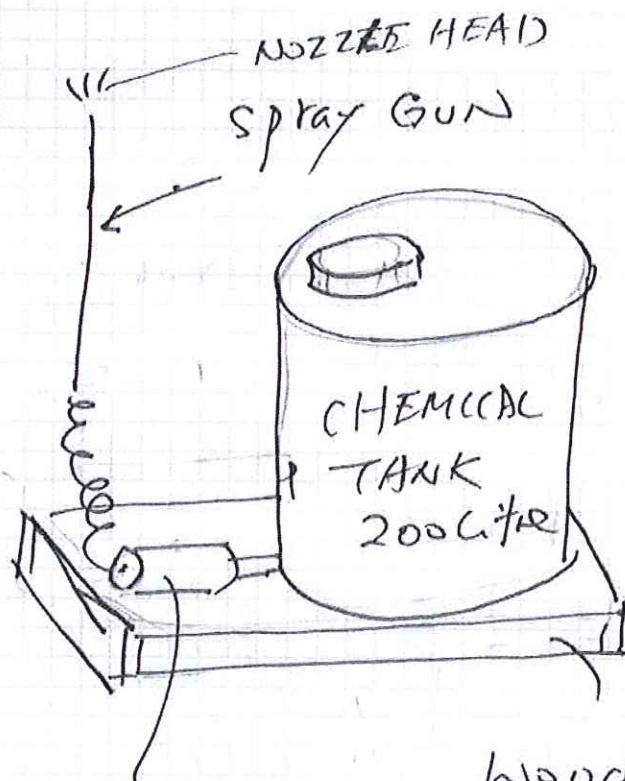

chemical spray
 pump
 220 volt
 15AMP
 230 Watts
 50 hz

wooden
 RACKET
 size
 1 meter
 x
 1 meter
 x
 0.1 meter

Weight
 300kg.



DRAW BY: DENNIS WONG
 AIR & WATER PURIFICATION EQUIPMENT CO. LTD

16 Dec 2010

**Appendix F – Product Data Sheet of
Wasmate 1501® Odor Reducer**

Wasmate 1501® Odor Reducer **Product Data Sheet**

Description

Wasmate 1501® Odor Reducer is a patented formulation designed to remove hydrogen sulfide and mercaptans odor situation. **Wasmate 1501® Odor Reducer** is an amine-based chemical product that will react with H₂S and mercaptans odor to form stable, liquid reaction products that are easily removed from the system. This product is non-hazardous and react immediately to product non-reversible, non hazardous stable compound.

Applications

Wasmate 1501® Odor Reducer injected into the process line or used in contact spray drop or mist.

Wasmate 1501® Odor Reducer for their H₂S odor removal needs , Landfill ,Wet slurry and Waste Water Treatment. Application procedures by industry are available upon request.

General Specifications

Appearance:.....	Clear to yellow Liquid
Specific Gravity @ 77°F:.....	1.012
pH:.....	10.8-11.5
Flash Point (TCC):.....	>200°F
Freezing Point:.....	-35°F

Use Requirements

The usage rate for in-line spray applications is around 1,000 liter wet slurry to use three liter of product (1000:3) that odor smell to be removed. The reaction efficiency is directly related to contact efficiency and time.

Wasmate 1501® Odor Reducer and the reacted solution are water-soluble, form no solids, and is readily biodegradable. There are no known undesirable side reactions that render the reacted product toxic or hazardous. It produces a stable, nonhazardous waste

Contract No. HY/2009/15

Central -Wan Chai Bypass – Tunnel (Causeway Bay Typhoon Shelter Section)

Benefits

- * Removal of H₂S & mercaptans odor in slurry, waste water treatment plant
 - * Preferentially reacts with H₂S odor compound in direct interact
 - * Removes H₂S odor from water and air and solid / wet slurry
- Safe water soluble reaction product
- Minimal Capital Investment
- Easy Disposal

Handling Precautions

This product is shipped in 20 or 200 litre poly drum, A Material Safety Data Sheet outlining recommended safe handling of this product attached in Annex A.

MATERIAL SAFETY DATA SHEET

Wasmate 1501 Odor Reducer

SECTION 1. Product Information

Product Name	Wasmate 1501 Odor Reducer
Manufacturer's Name and Address	Emergency Telephone Number
Air & Water Purification Equipment Co., Ltd	852 -31587941 ; 852 92127941
Flat g,21/F, Block 2,Kingswin Ind.,Bldg,32 Lei Muk Rd.,,	
Kwai Chung,N.T. Hong Kong	Effective: 6/99

Product usage : Odor Control

A deodorizer used to remove odorous gas by chemicals reaction used in waste water treatment plant, slurry waste soil, commercial and domestic application for odor suppression.

SECTION 2. – Hazardous Ingredients

This product contains no hazards ingredients. It is biodegradable deodorizer primarily composed of stabilizer, flow enhancer, bonding agents and surfactants which designed for hydroxyl reactivity with sulfides and ammonia. Trace amount of copper, iron, magnesium, and certain other minerals for chemical reaction. All other non hazardous ingredients are proprietary.

SECTION 3. - Physical/Chemical Characteristics

Product Identifier:	Wasmate 1501 Odor Reducer.	
Ingredients :	Sodium Chloride	CAS No. 7647-14-5
	Sodium Laureth Sulphate	CAS No.1335-72- 4
	Sodium Acetate	CAS No.127-09-03
	Sodium Bicarbonate	CAS No. 144-55-8
	Plant Extraction	
	Proprietary complex amine	CAS No. Proprietary
	Water	

Evaporation Rate = 1	Vapor Density >1	Specific Gravity (Water=1) 1.01-1.13 @ 20/20 C
pH : 9.6-11.3		Vapor Pressure(mm Hg) <0.01
Solubility in Water Completely soluble		
Boiling point 100 degree centigrade		
Appearance and Color Clear, Light Amber liquid		Freezing Point 3.8 C / 38.8 F

SECTION 4 - Fire and Explosion Hazard Data

Non-Flammable

SECTION 5 - Physical Hazards/Reactivity Data

Stability : Stable
Incompatibility : N/A
Hazardous Decomposition : N/A
Non-toxic
Non-poisonous.
Non-volatile.
Contain no alcohol.
Contains no pesticide or disinfectant
100 % biodegradable.
Soluble in water in any proportion.
Conform to the Air pollution Control (Volatile Organic Compounds) Regulation.

SECTION 6 - Health Hazards

Contain no hazardous ingredient.

SECTION 7 - Special Precautions and Spill / Leak Procedures

Precautions to be taken in Handling and Storage

Wasmate 1501 Odor Reducer is a safe product. Wasmate 1501 is accidentally splashed in the eyes or on the skin, flush with water. If Wasmate 1501 Odor Reducer is accidental ingested, drink large amount of water.

SECTION 8 - Special Protection and Control Measures

Respiratory Protection

None expected to be needed.

Revision: 19/02/2010

The data contained herein is based on information currently available to Air & Water Purification Equipment Co., Ltd. and believed to be factual and the opinions expressed to be those of qualified experts; however, this data is not to be taken as a warranty or representation for which Air & Water Purification Equipment Co., Ltd.

Wasmate 1501 Odor Reducer

Description:

Wasmate 1501 Odor Reducer is a proprietary liquid deodorant solution for STRESSED conditions that utilizes the very latest hydroxyl technology to reduce odor. Suppressant & masking media working with conventional chemistry provide odor reduction at low product feed rates (refer to laboratory study). It contains non-hazardous ingredient. The product is non toxic, non poisonous, non flammable, non volatile, CFC free, non alcohol, 100 % biodegradable and soluble in water.

Application/Federate

Wasmate 1501 Odor Reducer can be used in air and water systems that contain Hydrogen Sulfide and Ammonia odor. It can be sprayed into the air as a fine mist, or mixed with water into liquid media. Because the surfactants bond with the odor causing molecules, the smell are suppressed and masked, but also precipitated out of the air or water. This reaction reduces the negative impact of odor molecules to human health.

Suggested application in waste treatment plant, rubbish station, public toilet, pig farm.

Testing & Control

See your service rep. for details & recommended instruction.

Feeding

Feed product from a feeding device. Dosage will be recommended by service rep.

Packaging/Storage/Handling

Packaged in 20-liter drum. Handling and storage follow MSDS suggestion. Properly stored product will remain effective 6 months. Suggest to store in cool, dry area.

The above information is based on data available to us and is believed to be correct. As the conditions or methods of use are beyond our control, we do not assume any responsibility and expressly disclaim any liability for any use of this material and this information is furnished upon the condition that the person receiving it shall make his own determination for the suitability of the material for his particular purpose. The information contained herein is believed to be true and accurate but all statements or suggestions are made without warranty, expressed or implied, regarding the accuracy of this information, the hazards connected with the use of the material, the results to be obtained from the use thereof, or any such use will not infringe any patent. Compliance with federal, state, and local laws and regulations remain the responsibility of the user.

Distributed By : Air & Water Purification Equipment Co., Ltd Address : 21/F., G, Kigswin ind., Bldg., 32 Lei Muk Rd, Kwai Chung, N.T. Fax : 852 31586138 Tel : 852 31587941

Appendix G – Proposal on the 24-hr Turbidity Monitoring System



Proposal on the 24-hour Turbidity Monitoring System

Introduction

A 24-hr monitoring system of turbidity shall be set up around the works sites at Causeway Bay Typhoon Shelter during the dredging of sediment at the south-western corner of the Causeway Bay Typhoon Shelter. This proposal presents the details of system configuration and installation details for the monitoring system.

Equipments

Component equipments of the turbidity monitoring are listed below. Details of equipments are as follows. Specifications of proposed equipments and job reference are shown in **Appendix A**.

1. Turbidity Sensor – Turbimax CUS31
2. Turbidity and Suspended Solid Transmitter – Liquisys M CUM 223
3. Automatic cleaner – Cleanfit CUA451
4. Data recorder – Ecograph T RSG30
5. Weatherproof Cabinet with louvers, approximate dimension 0.5m X 0.5m X 0.6m to house the Transmitter, data recorder and modem
6. Wireless modem (GPS or equivalent mechanism)
7. Dual sampling pump system – TSURUMI TOK50PU2.75 and automatic control

Proposed Monitoring Location

The proposed monitoring locations are C6 – Proposed Exhibition Station / World Trade Centre and C7 – Windsor House. The monitoring stations will be located near the seawall of the Intake of C6 and C7. Figure 1 shows the proposed location of the monitoring stations.

Methodology for Installation

1. The monitoring station, and any of its parts/components, shall be suitably designed/sized to operate continuously for 24 hours. Key components of station, except the submersible pump and associated pipe work, shall be housed in a weatherproof chamber. Typical dimension of the weatherproof chambers (subject to variation with respect to actual site constraint) are as follows:
 - Turbidity monitoring system : 400mm(W) x 500mm(H) x 260mm(D)
 - Submersible pump control : 800mm(W) x 1000mm(H) x 260mm(D).
2. A dual pump system shall be installed for duty-standby operation for continuous sampling for monitoring at the turbidity sensor. The pump itself and all associated pipe work shall include valves and flow protection sensor to counteract against suction force from the intake and to protect from damage due to any blockage.
3. The turbidity measurement shall be conducted by the extraction of raw marine water influent via the water pipe. The turbidity sensor shall be located in the ascending and horizontal pipe.

4. A pump skid (with pre-fabricated vertical pipework and guide-rail) shall be fixed using screwdriver at the mid-depth level close to the intake (approximate 6m below the ground level).
5. Connection to a/c power supply (for both installation and operation) shall be provided and ensured by the owner of the installed site (proposed to be Sun Hung Kai at C6 and Windsor House at C7).
6. Tentatively 6-7 mandays shall be required for mobilization to site and installation of monitoring station. The programme of the tentative installation schedule and commissioning period is attached in **Appendix B**.
7. Installation details shall be referred to the diagrammatic illustration as shown in **Figure 1**.

Methodology for Operation

1. The systemic drawing is attached in **Appendix C**. The monitoring system shall be capable of fully automatic operation and the logged data shall be linked up with the central database.
2. Testing and commissioning of the stations shall be conducted for at least 14 days before the commencement of the actual monitoring.
3. Water around the intake is automatically pumped via the sampling pump for flowing through the turbidity sensor.
4. The turbidity sensor can be cleaned by automatic cleaner regularly so as to avoid the particles trapping on the sensor surface. The wiper of automatic cleaner is recommended to operate once per 30 minutes. Each wiping time is recommended to preset to 30 seconds.
5. Data logger shall capture data every 5 minutes. The data shall be transmitted daily through GSM wireless communication or equivalent device to head office computer server by mobile dial up mechanism
6. The data shall be audited and compared with the Action and Limit level determined during the baseline water quality monitoring at the cooling water intake locations within two working days of sampling and audited data shall be posted onto EM&A website for public access two working days after sampling
7. Regular checking of monitoring system shall be maintained at least once per week so as to keep the consistency of the real-time turbidity monitoring.
8. It is recommended that calibration shall be carried out at 3 monthly intervals throughout all stages of the works of dredging of sediment. The suspension time of monitoring is expected approximate 1-2 hours during the calibration. The process of calibration is attached in **Appendix D**.

Compliance Checking of Data

In case of any action and limit level exceedances occur, the exceeded result will be analysed and reviewed any relationship with the construction works. Shall the non-compliance occurs, action shall be taken in accordance with the Event/Action Plan stipulated in EM&A Manual.



FIGURE 1

Proposed Location of Monitoring Stations

Figure 1 Layout Plan for the Monitoring Stations

Legend

● Proposed Location of Monitoring Station

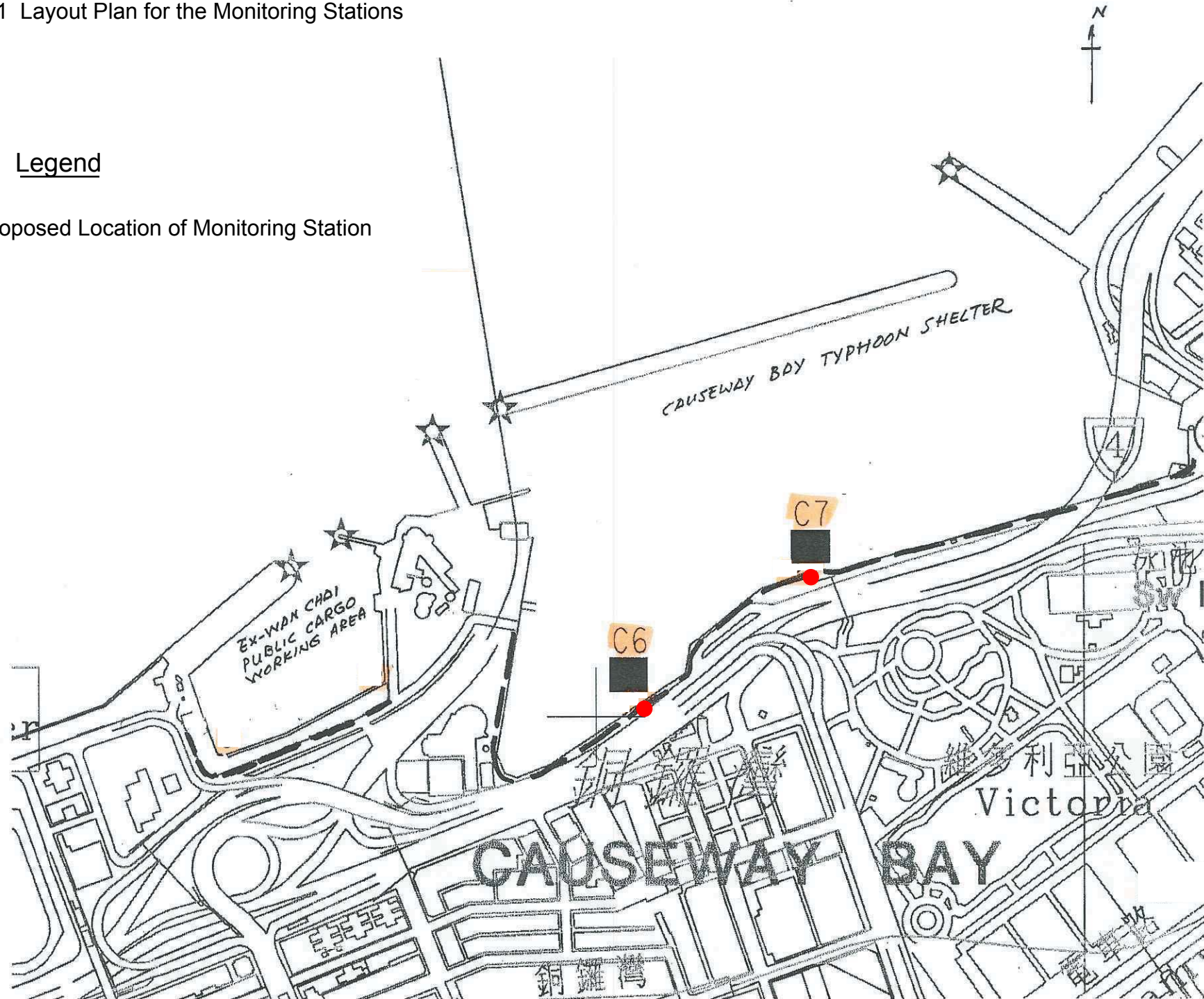

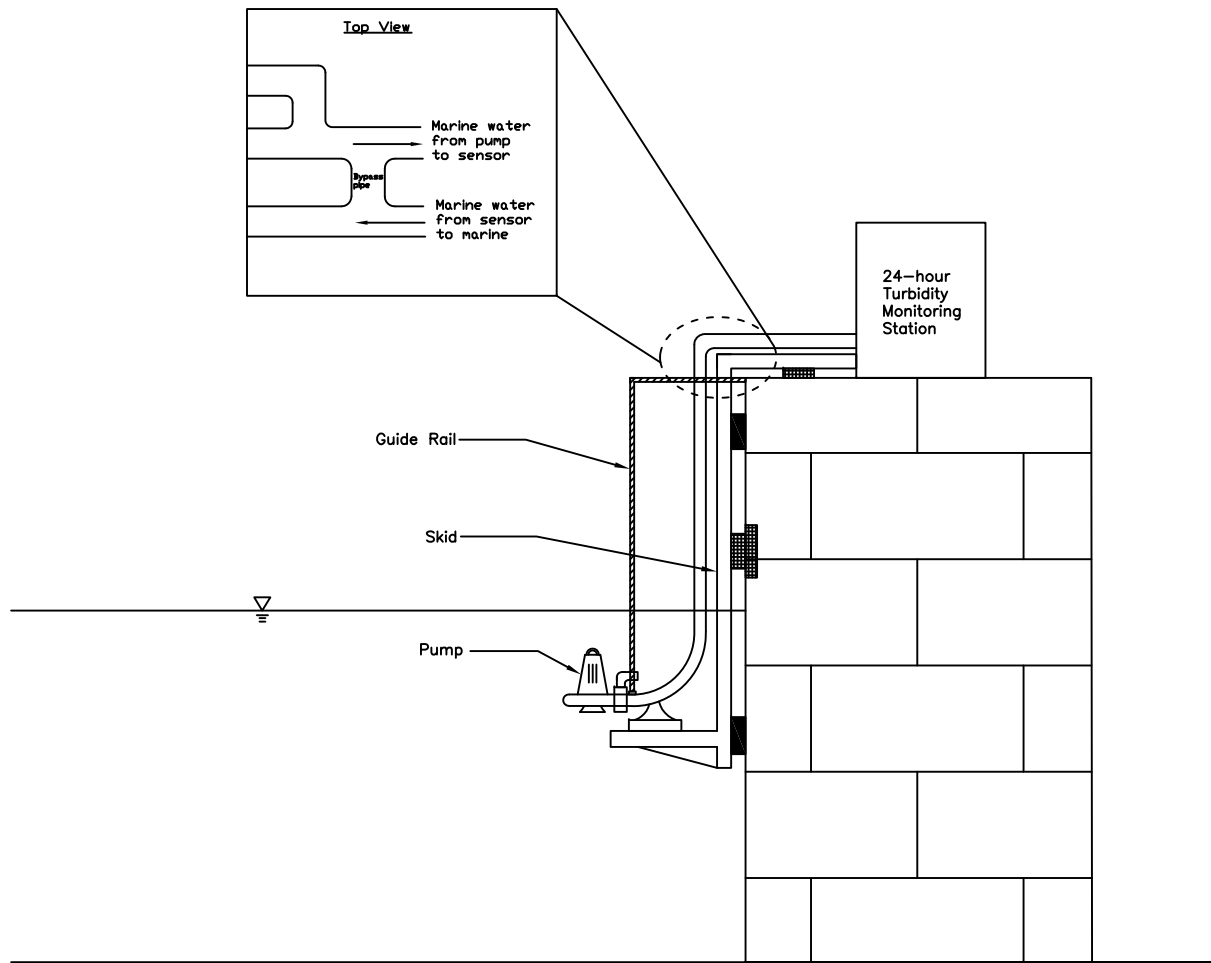

Sequence of Installation

1. Mobilization or pre-fabricated equipment to site
2. Unloading of equipment for installation (by hand tools)
3. Fixing of skid and guide rail
4. Pumping installation
5. Pipework installation
6. Electrical installation
7. Mounting equipment installation

LEGEND



-  Support Point by Seawall
-  Fixed Point to be conducted during mid-ebb tide
-  Pump skid with pre-fabricated vertical pipework and guide-rail

Figure 1

Layout Plan for Monitoring Stations at C6 – Excelsior Hotel



Legend



-  Route of the water pipes
-  Route of the electric cable
-  Weatherproof cabinet installed with monitoring equipment

Figure 1 Layout Plan for Monitoring Stations at C6 – Excelsior Hotel



Legend

- Route of the water pipes

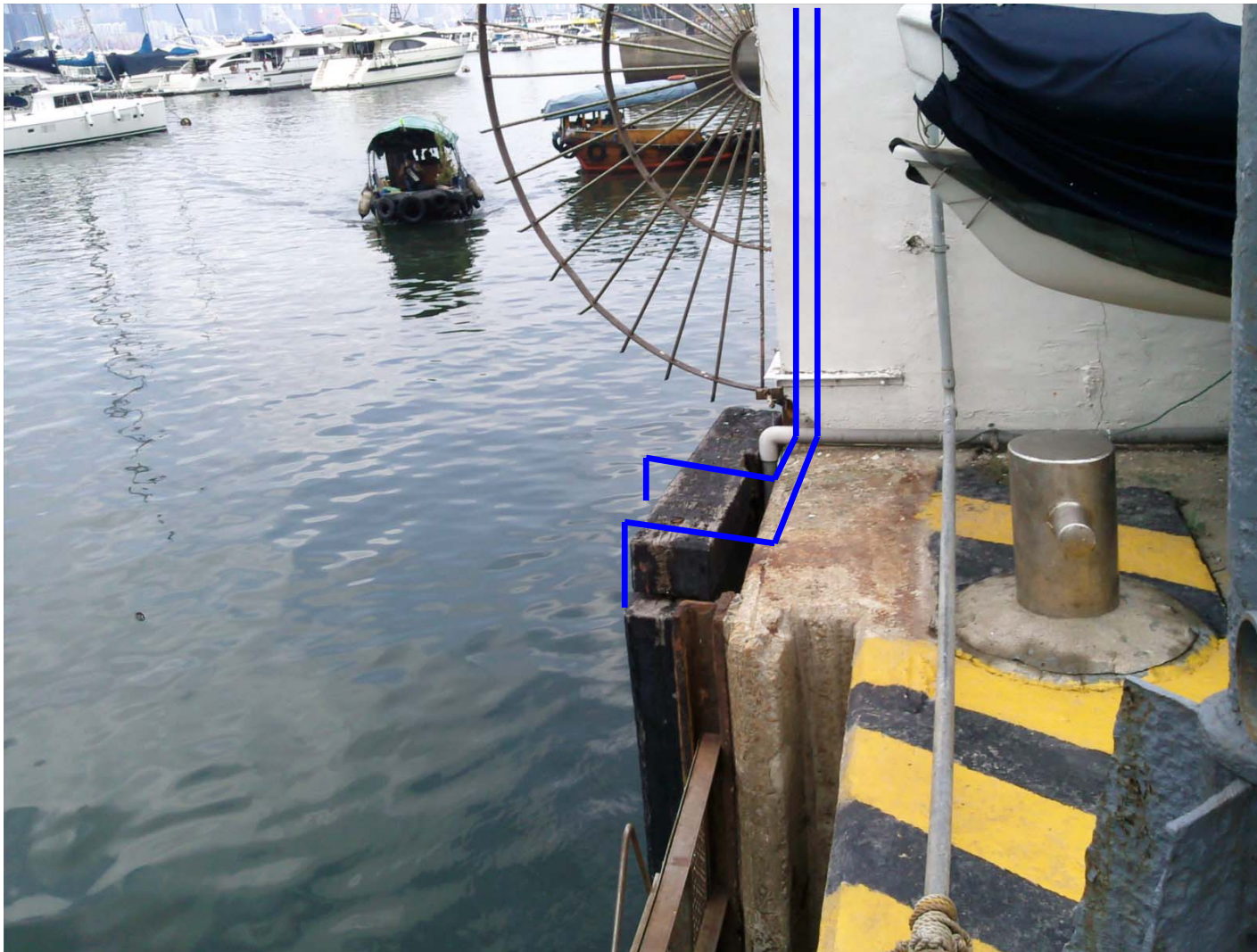
Proposed location to be located the dual sampling pump system

Figure 1 Layout Plan for Monitoring Stations at C7 – Windsor House



Legend



-  Route of the water pipes
-  Route of the electric cable
-  Weatherproof cabinet installed with monitoring equipment

Figure 1 Layout Plan for Monitoring Stations at C7 – Windsor House



Legend

— Route of the electric cable



APPENDIX A

Specifications of Proposed Equipments and Job Reference

Retractable Assembly *CleanFit CUA 451*

**Manually operated stainless steel assembly
with ball valve
for the turbidity sensors CUS 31, CUS 41 and CUS 65**

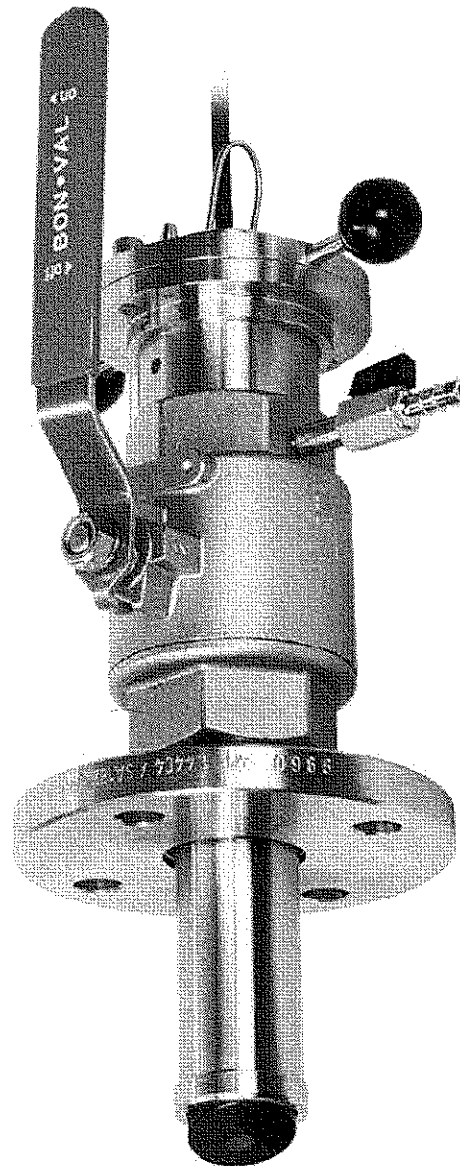

Application

- Primary sludge and return activated sludge in sewage treatment plants
- Sludge centrifuge monitoring
- Filter monitoring and filter backwash
- Monitoring of phase break processes
- Cooling water monitoring

Your benefits

- Safety:
 - Safe and reliable process termination possible under nearly all conditions
 - Process pressure up to 10 bar (145 psi), manually operated up to 2 bar (29 psi)
- Comfortable operation:
 - Cleaning possible due to rinse water connection
 - Rinse water connection can be used as sealing water inlet
 - Sensor monitoring and cleaning without process interrupt

Function and system design

Function



The assembly is manually operated.

Caution!

The air relief valve and the rinse connections (if used) are in open contact with the medium in the measuring position, or at least when moving, and are thus exposed to the process pressure. Make sure that, the air relief valve and the rinse connections (if used) are closed when moving the assembly .

General sequence when moving the retractable assembly

- from position "Service" to position "Measure"
 - Open the ball valve (see fig. below, pos. 1)
 - Move the sensor into the process: press down the handle (pos. 6) of the sensor holder (pos.3)
 - Close the bayonet joint (pos. 5)
 - Fasten the fastening screws (pos. 4)
- from position "Measure" to position "Service"
 - Loosen the fastening screws
 - Open the bayonet joint
 - Move the sensor off the process: pull up the sensor holder by means of the handle
 - Close the ball valve

In the "Service" status (sensor moved back into the assembly and **ball valve closed**), the ball valve seals the assembly off from the process. This means that cleaning and calibration can take place and electrodes can be changed without interrupting the process.



Caution!

Manually moving the assembly under process conditions is only possible at a process pressure up to 2 bar (29 psi).

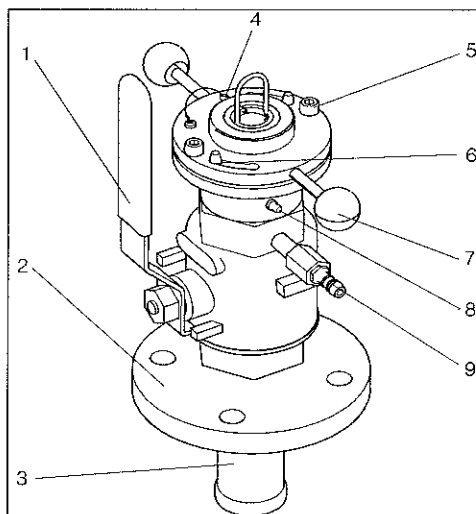

Assembly in measuring mode (ball valve open)

- 1 Hand lever for ball valve open/close
- 2 Process connection (Flange DN 50 / PN 16)
- 3 Outer sleeve
- 4 Locking pin
- 5 Fastening screws
- 6 Bayonet joint
- 7 Handle
- 8 Lubricator nipple
- 9 Air relief valve resp. rinse water connection

Measuring system

A complete measuring system comprises:

- CleanFit CUA 451 assembly
- TurbiMax W CUS 41/CUS 31 or TurbiMax W CUS 65 (with CUM 740 only) turbidity sensor
- Liquisys M CUM 223/253 or CUM 740 (with CUS 65 only) transmitter

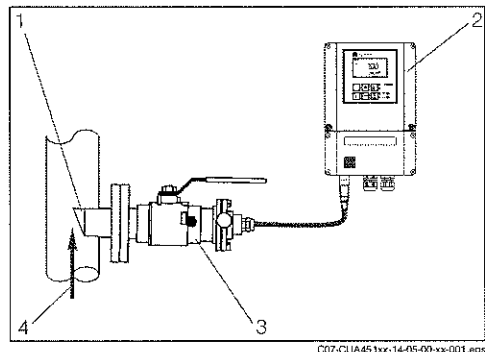

Measuring system with CUS 31 resp. CUS 41

- 1 CUS 31 or CUS 41
- 2 Liquisys M CUM 253
- 3 CUA 451
- 4 Medium flow direction

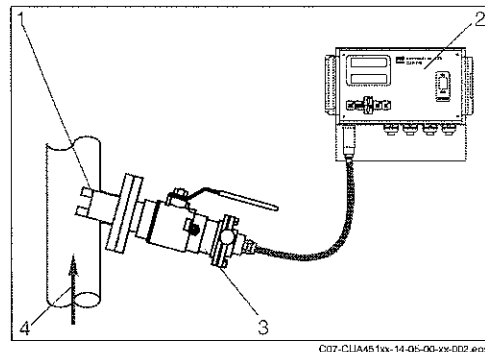

Measuring system with CUS 65

- 1 CUS 65
- 2 CUM 740
- 3 CUA 451
- 4 Medium flow direction

Installation

Installation conditions

Install the assembly at places with constant flow. The minimum pipe diameter is DN 80.

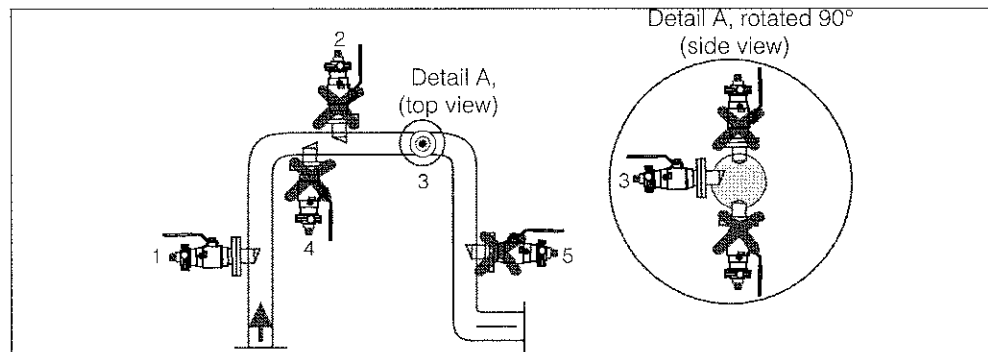

Permissible and impermissible sensor installation positions

- 1 Ascending pipe, best position
- 2 Horizontal pipe, sensor top down, impermissible due to air cushion or foam bubble forming
- 3 Horizontal pipe, installation with permissible emitting angles (acc. to sensor version)
- 4 Overhead installation, impermissible due to suspended particle settling on the sensor optics
- 5 Down pipe, impermissible



Note!

- Do not install the assembly at places, where air cushions or foam bubbles can be formed or where suspended particles can settle on the sensor optics (→ Fig.).
- Measuring errors can occur, if:
 - the sensor is not immersed into the medium
 - suspended particles are settled on the sensor optics.

Orientation

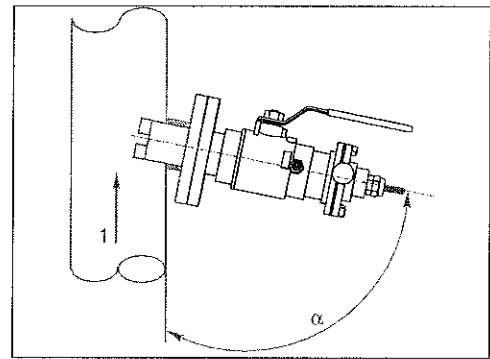
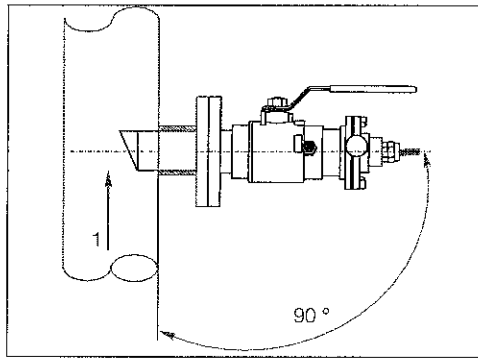

Orientation with CUS 41

1 Medium flow direction

Orientation acc. to sensor version:

- CUS 31, CUS 41, CUS 65-B: $\alpha = 90^\circ$
- CUS 65-A: $\alpha = 80^\circ$
- CUS 65-C, E: $\alpha = 100^\circ$
- CUS 65-D: $\alpha = 110^\circ$

Orientation with CUS 65

α depending on sensor version, see below

1 Medium flow direction

Environment

Ambient temperature range 0 ... 50 °C (32 ... 122 °F)

Process

Medium pressure max. 10 bar (145 psi)



Caution!

- The maximum process pressure is 2 bar (29 psi) for manual assembly operation!
- Please consider the sensor process conditions!

Medium temperature 0 to 80 °C (32 to 176 °F)



Caution!

Please consider the maximum sensor process temperature!

Pressure-temperature diagram

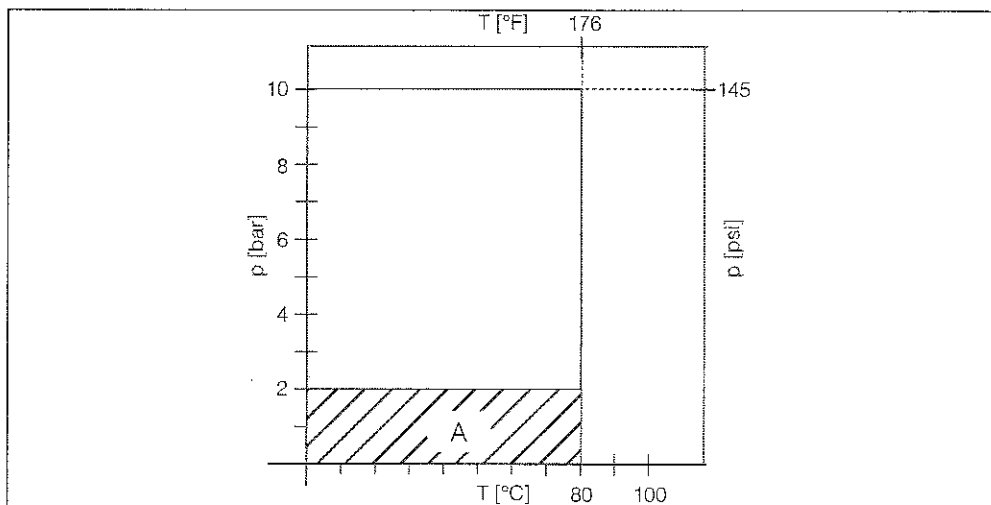

Pressure-temperature diagram

A Manual operation range

Mechanical construction

Design, dimensions

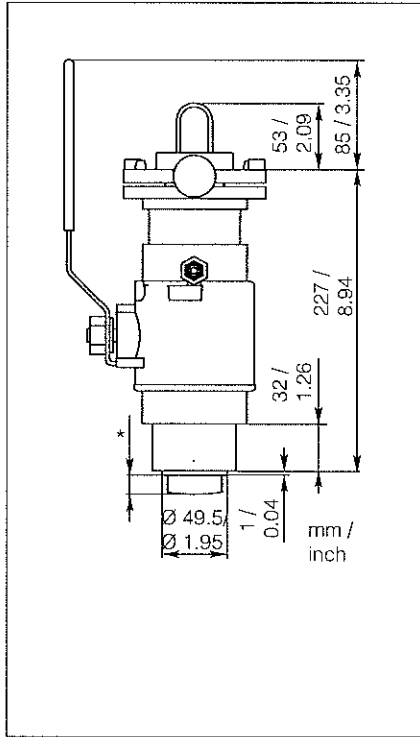

C07-CUA451xx-06-07-en-003.eps

Assembly with welding neck (short lift)

* Dimensions depend on sensor, see below

*** There must be additional space of 350 mm (13.78") for sensor installation!

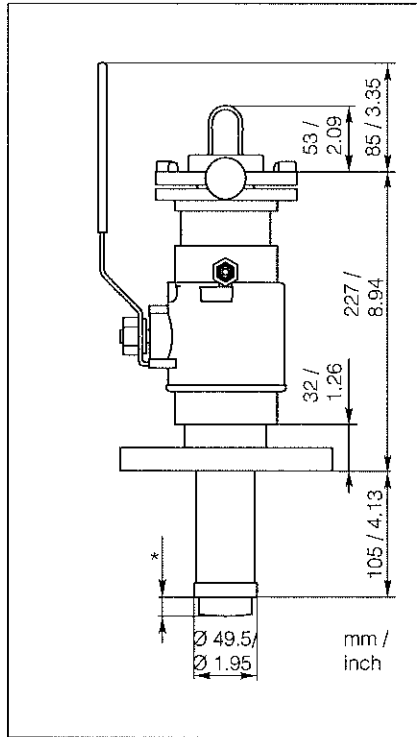

C07-CUA451xx-06-07-en-002.eps

Assembly with flange connection (long lift)

* Dimensions depend on sensor, see below

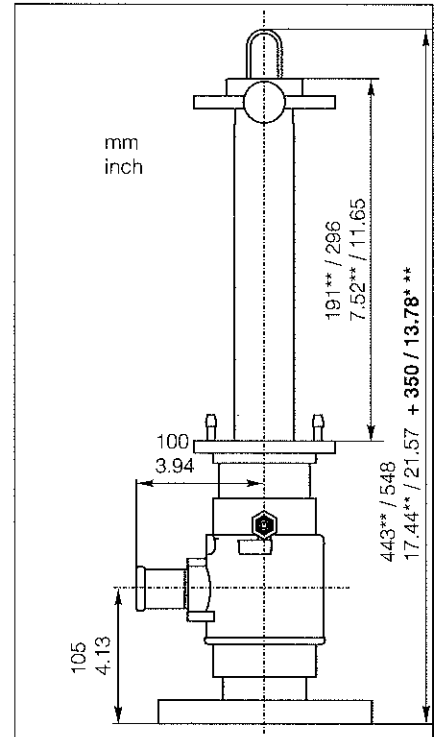

C07-CUA451xx-06-07-00-en-001.eps

Assembly in service position

** Assembly version with short lift (see product structure)

* Dimension acc. to sensor type:

CUS 31/41: 14 mm (0.55") / 20 mm (0.79") with wiper

CUS 65-A/B: 19 mm (0.75")

CUS 65-C: 12 mm (0.47")

CUS 65-D: 10 mm (0.39")

CUS 65-E: 7 mm (0.28")

Fitted sensors

CUS 41 / CUS 31 or
CUS 65

Weight

8 - 11 kg (17.6 ... 24.3 lb) depending on the assembly version

Materials

In contact with medium:

Viton (seals)

stainless steel 1.4404 (AISI 316L)

nickel brass (air relief valve resp. rinse connection)

Not in contact with medium:

stainless steel 1.4404 (AISI 316L)

Process connections

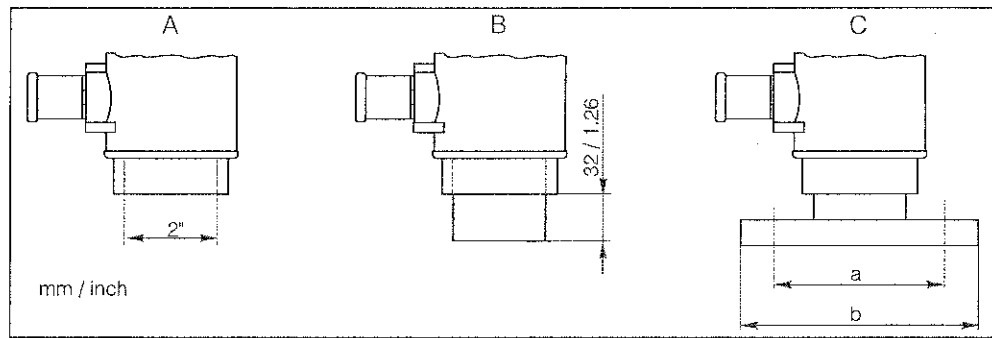

Process connections

- A Internal thread G2
- B Internal thread G2 with welded fitting
- C Flange DN 50 / PN 16 and Flange ANSI 2" / 150 lbs
 a: DN 50: Ø 125 (4.92"), ANSI 2": Ø 120.7 (4.75")
 b: DN 50: Ø 165 (6.50"), ANSI 2": Ø 152.4 (6.00")

Rinse connection fitting

2 x G1/8 (internal)
 Connection options:
 – 2 x ball valve with hose connection OD 9 mm (0.35"), see accessories
 (One ball valve is in the scope of delivery. When used alone, it is an air relief valve.)
 – customer specific solution, rinse connections with G1/8 external thread

Air relief valve

Hose connection OD 9 mm (0.35")

Ordering information

Product structure

Sensor lift / Immersion depth	
A	Short lift, Immersion depth approx. 170 mm / 6.69" (process connections A and B only)
B	Long lift, Immersion depth approx. 270 mm / 10.63"
Sensor type / Connection	
1	For CUS 31/41 with G1, Sensor length approx. 200 - 220 mm / 7.87 - 8.66"
2	For CUS 65 with G1, Sensor length approx. 140 - 160 mm / 5.51 - 6.30"
Process connection	
A	G2 internal thread
B	G2 internal thread with welded fitting h = 50 mm / 1.97"
C	Flange DN 50 / PN 16 acc. to EN 1092/1
D	Flange ANSI 2" / 150 lbs
CUA 451-	complete order code

Accessories

Assembly

- Ball valve for rinse connection; order no. 51512982
- O-ring set, Viton; order no. 51512981

Process connection adapter

- Welded fitting for pipe diameters of more than 80 mm (3.15"), with combination flange DN 50 / ANSI 2":
 - Bore holes for DN 50 flange: 4 x 90° Ø18 (0.71") on hole circle Ø125 (4.92")
 - Bore holes for ANSI 2" flange: 4 x 90° Ø19 (0.75") on hole circle Ø121 (4.76")
- Flange seal, 4 screws M16x60, 4 nuts M16 incl. washers, stainless steel 1.4571 (AISI 316Ti); order no. 50080249

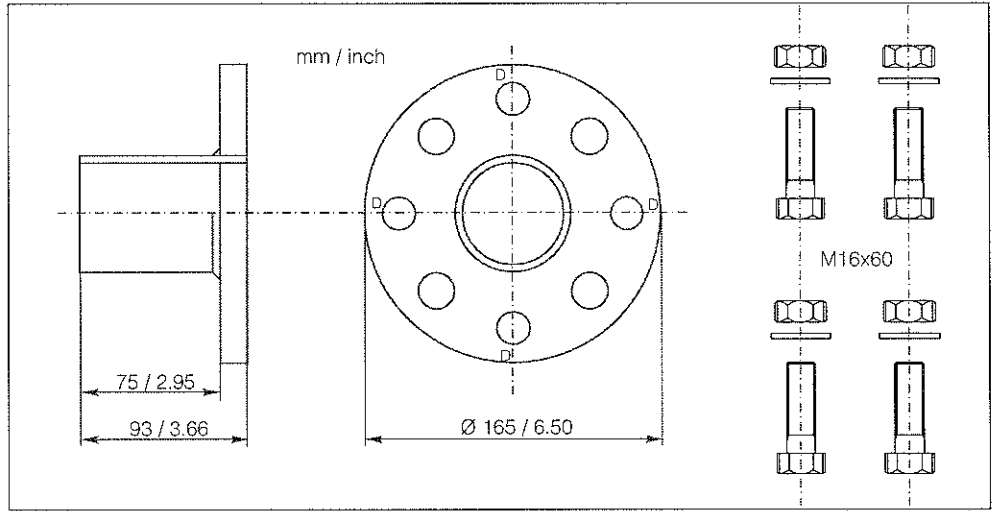

Welded fitting

D: Marks for the bore holes of the DN 50 flange

- Welded rinse fitting DN 65,
 - for automatic cleaning of CUS 31/41 sensors in pipe lines and tanks:
 - Bore holes for DN 50 flange: 4 x 90° Ø18 (0.71") on hole circle Ø125 (4.92")
 - Bore holes for ANSI 2" flange: 4 x 90° Ø19 (0.75") on hole circle Ø121 (4.76")
 - Rinse connection: external thread R $\frac{1}{4}$
 - with removable spray head
 - up to 6 bar (87 psi), 80 °C (176 °F)
- order no. 51500912

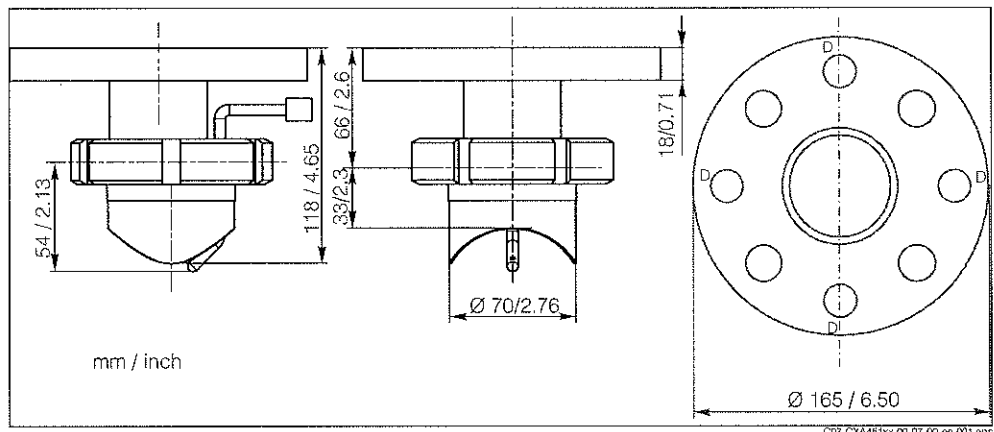

Welded rinse fitting

D: Marks for the bore holes of the DN 50 flange

Sensors

- TurbiMax W CUS 31
Turbidity sensor for drinking water and waste water applications, 90 ° scattered light method
ordering acc. to product structure, see Technical Information
- TurbiMax W CUS 41
Turbidity sensor for waste water and solid content measurements, 90 ° scattered light method
ordering acc. to product structure, see Technical Information
- TurbiMax W CUS 65
Turbidity and solid content sensor with various measuring range applications,
backscatter-light method
ordering acc. to product structure, see Technical Information

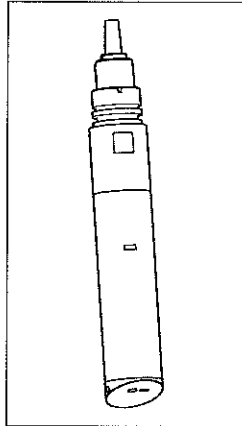

C07-CUS31xxx-00-05-06-xx-001.eps
TurbiMax W CUS 31 / 41

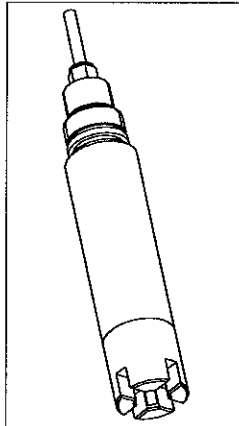

C07-CUS65xxx-00-05-06-xx-001.eps
TurbiMax W CUS 65

Profiling plates

- Profiling plates for welded fittings;
order no. 51513623

Documentation

- Operating Instructions CleanFit CUA 451, BA 369C/07 (order no. 51512838)
- Technical Information TurbiMax W CUS 31, TI 178C/07 (order no. 50088400)
- Technical Information TurbiMax W CUS 41, TI 177C/07 (order no. 50088402)
- Technical Information TurbiMax CUS 65, TI 370C/07 (order no. 51512873)

Endress+Hauser GmbH+Co. KG
Instruments International
P.O. Box 2222
D-79574 Weil am Rhein
Germany

Tel. (07621) 975-02
Tx 773926
Fax (07621) 975 345
e-mail: info@ii.endress.com

Internet:
<http://www.endress.com>

Endress + Hauser
The Power of Know How



Turbidity/Suspended Solids Measurement

Liquisys M CUM 223 / 253

Turbidity and Suspended Solids Transmitter



Liquisys M CUM 223

Liquisys M CUM 253

Due to the modularity of its design, the Liquisys M CUM 223 / 253 transmitter can be adapted to a wide range of customer needs. The basic version, which provides simple measuring and alarm signalling functions, can be equipped with additional software and hardware modules to match specific applications. Retrofitting of expansion modules is also possible.

Areas of application

- Sewage treatment plants, suspended solids measurement
- Effluent treatment
- Water treatment and monitoring
- Drinking water
- Surface water: rivers, lakes, ocean
- Service water
- Indirect discharge
- Water recycling

Benefits at a glance

- Measuring transmitter in field or panel-mounted housing
- Universal application
 - One instrument for turbidity and suspended solids
 - Units: FNU (formazine standard), ppm, g/l, % or % SS
- Simple handling
 - Logically arranged menu structure with plain text in 6 languages facilitates instrument configuration
 - Large, two-line display indicates measured value and temperature at the same time
 - Ultrasimple calibration with user samples and alarm signalling for calibration errors
- Safe operation
 - Overvoltage (lightning) protection according to EN 61000-4-5
 - Direct access for manual contact control
 - User-defined alarm configuration for alarm contact and error current
 - Sensors are factory-calibrated with formazine standard and SiO₂
 - Automatic sensor self-recognition with calibration data transfer

The basic unit can be extended with:

- 2 or 4 contacts for use as:
 - Limit contacts (also for temperature)
 - P(ID) controller
 - Timer for simple rinse processes
 - Complete cleaning with Chemoclean
- Plus package:
 - Any current output configuration via table
 - Automatic initiation of cleaning in case of alarm or limit violation
 - Display in customer units (e.g. density) via table assignment
 - Live check of sensor
- HART® or PROFIBUS-PA
- 2nd current output for temperature

Quality made by
Endress+Hauser



ISO 9001

Endress + Hauser

Nothing beats know-how



Details

Liquisys M CUM 223 / 253 provides a solution for all drinking water processing, process water and sewage treatment applications.

Features of the **basic version (TU)**:

Measurement of turbidity or suspended solids

This is selected via the menu. During measurement, the value measured can be displayed in the other measuring mode. The **temperature** is displayed at the same time if desired.

2.4 / 22 mA		
E 057	yes	no
E 080	no	yes
----	yes	no

Different alarms are required depending on application and operator. Therefore the Liquisys M CUM 223 / 253 permits independent **configuration of the alarm contact and error current** for each individual error. Unnecessary or undesirable alarms can be suppressed in this manner.

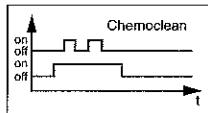
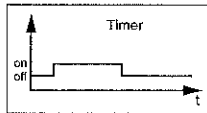

Up to four contacts can be used as limit contacts (also for temperature), to implement a P(ID) controller or for cleaning functions.

Direct **manual operation of the contacts** (bypassing the menu) provides quick access to limit, control or cleaning contacts, permitting speedy correction of deviations.

Instrument DATA	
SETUP HOLD	
SerNo	E113
12345678	

The **serial numbers** of the instrument and modules and the order code can be called up on the display.

The **TS version** version provides **additional functions:**

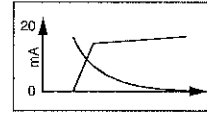

In order to display wide measuring ranges while still achieving a high resolution in specific ranges, the **current output** can be configured as required via a table. This permits **bilinear** or **quasi-logarithmic** curves, etc.

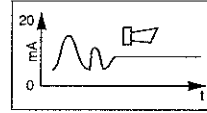

The **live check** issues an alarm when the sensor signal does not change over a defined period of time. This may be caused by blocking, passivation, separation from the process, etc.

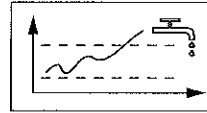

Soiling quickly results in excessive measured values. **Automatic cleaning** prevents alarms and inaccuracy caused by soiling.

In addition to concentration (ppm / % SS), **the display can also show other units** (e.g. density). A table is used for conversion (calibration in %).

Basic version and plus package

	Basic version	With plus package (TS version)
Alarm signalling	MEASUREMENT CALIBRATION (3-pt. / 1-pt. / reflection) Read instrument DATA Linear CURRENT OUTPUT CURRENT OUTPUT simulation 1 programmable ALARM CONTACT (contact and error current)	LIVE CHECK of sensor CURRENT OUTPUT programmable (table)
	<i>Additional features</i>	<i>Additional features</i>
Controlling	2 CHANGEOVER CONTACTS for - Measuring parameter limit - Temperature limit - P(ID) controller - Timer for cleaning	Concentration measurement with assignment to other units Automatic cleaning triggered by alarm or limit violation
	<i>Additional features</i>	<i>Additional features</i>
Cleaning	2 more CHANGEOVER CONTACTS (total of 4) for - Measuring parameter limit - Temperature limit - P(ID) controller - Chemoclean cleaning (water and cleaning agent)	Cleaning triggered externally or automatically by alarm or limit violation

Measuring and control system

A complete measuring system comprises:

- the turbidity/suspended solids transmitter Liquisys M CUM 223 or CUM 253
- a turbidity sensor CUS 31 or suspended solids sensor CUS 41, and

- an immersion, flow or retractable assembly

Options:

- extension cable CYK 8, and
- junction box VBM.

Complete measuring systems with Liquisys M CUM 223 / 253

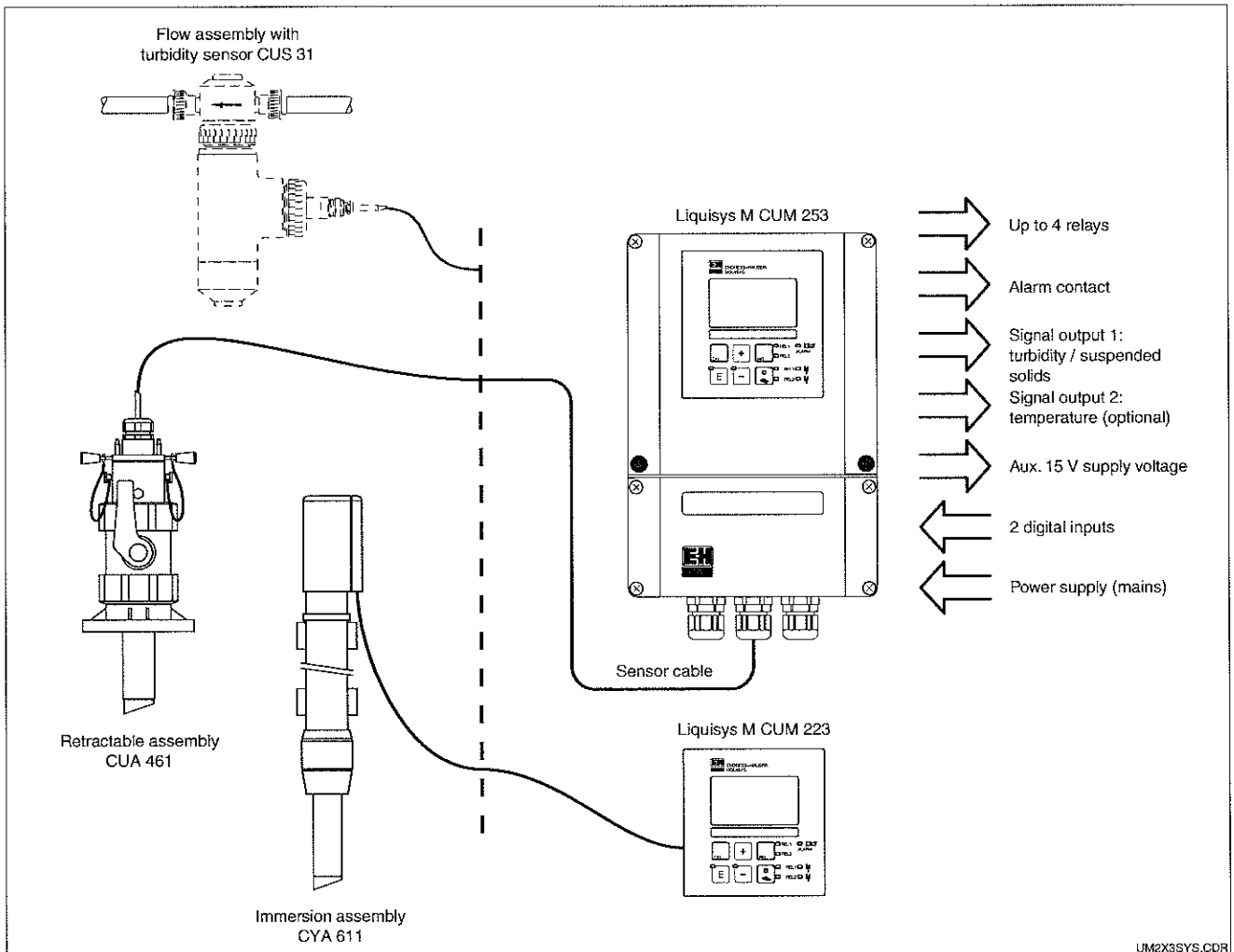

UM2X3SYS.CDR

Operation

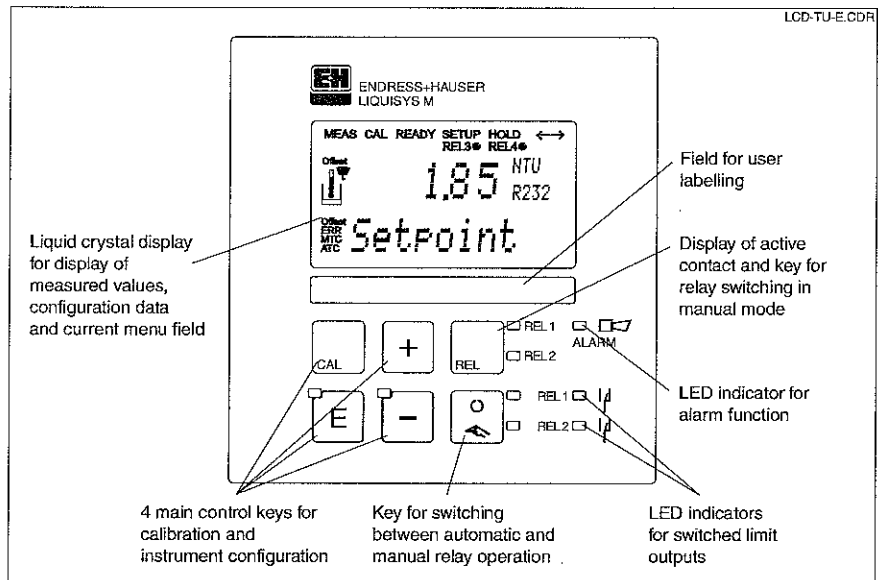

Everything at a glance

The display simultaneously shows the current measured value and the temperature – the essential process data. Brief informational texts in the configuration menu provide assistance with parameter configuration.

Intelligent and simple

All instrument control functions are arranged in a logical menu structure. Following access code entry, the individual parameters can be easily selected and modified as needed.

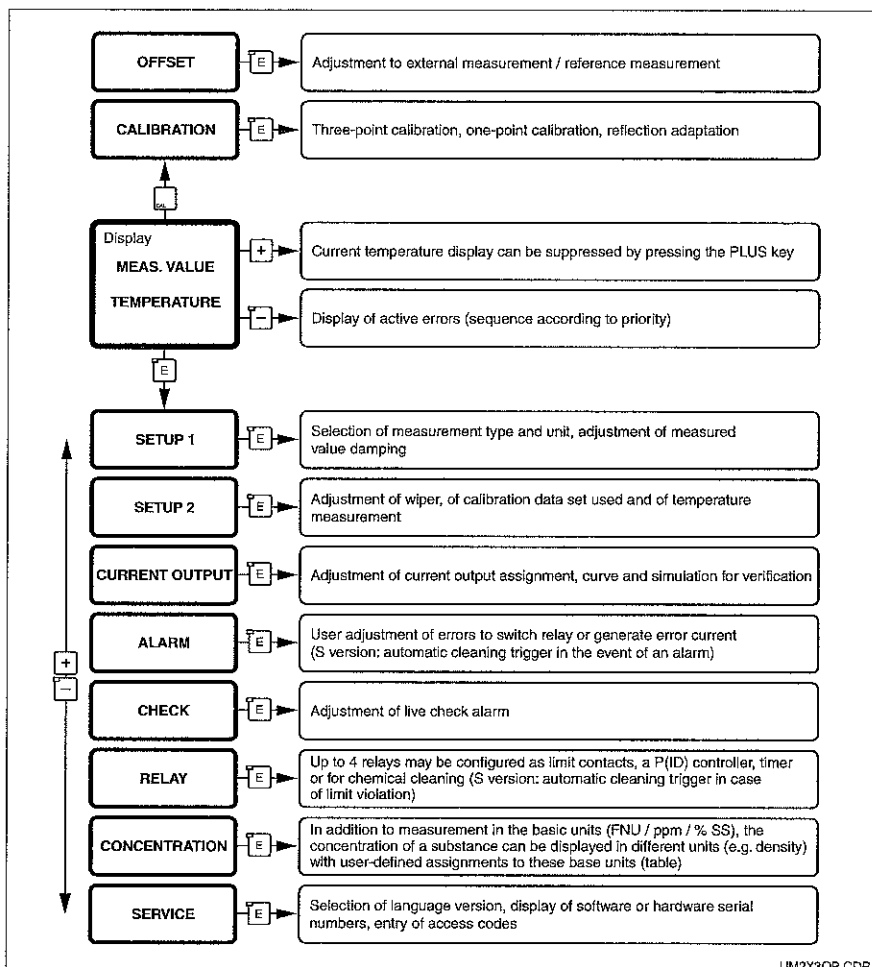

Electrical connection

All connections to the panel-mounted instrument CUM 223 are established via the terminal strips on the rear. In the case of the field instrument CUM 253, all wires (including the sensor cable) are connected to terminals in a separate wiring compartment.

All the wiring can remain in place if the instrument needs repair because all possible repairs are limited to assembly replacement. So, Dismantling the instrument and rewiring are no longer necessary.

Left:
Liquisys M CUM 223,
connections on the rear
of the instrument

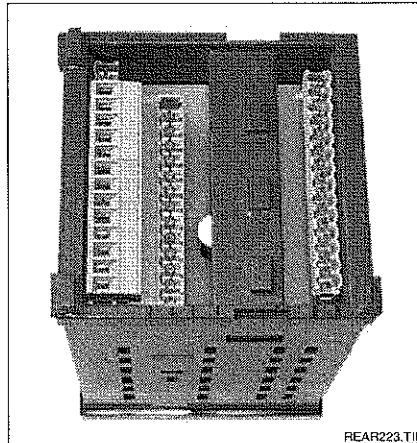

Right:
Liquisys M CUM 253,
rear of instrument with
replaceable electronics
box (E)

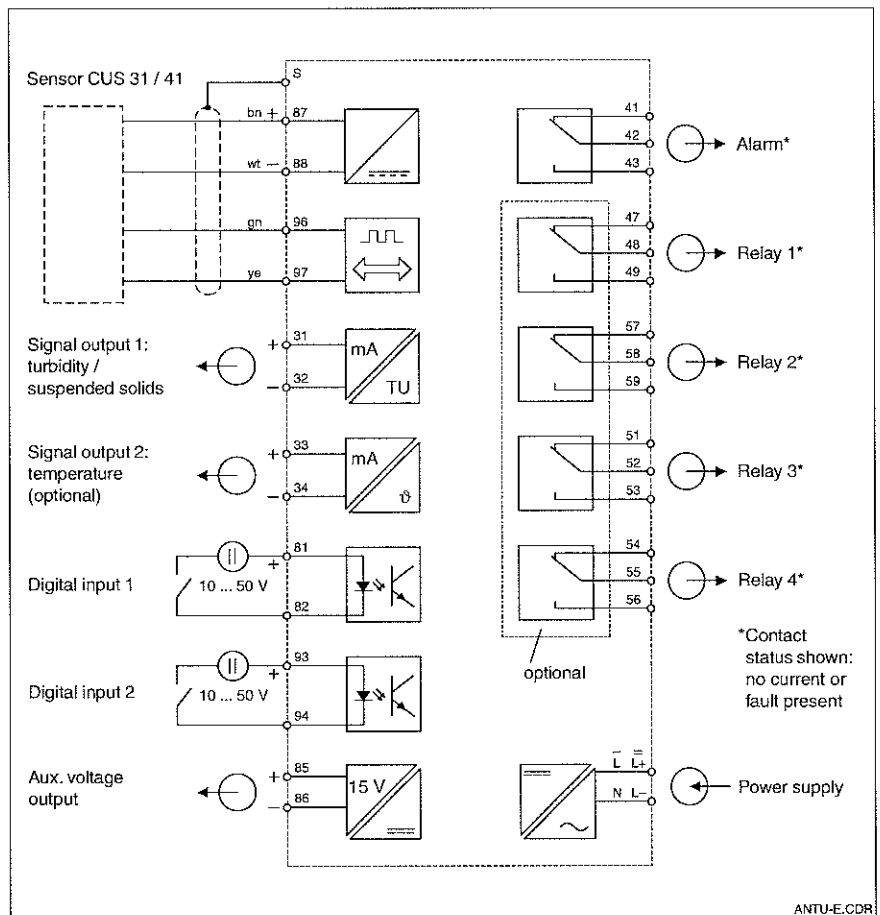
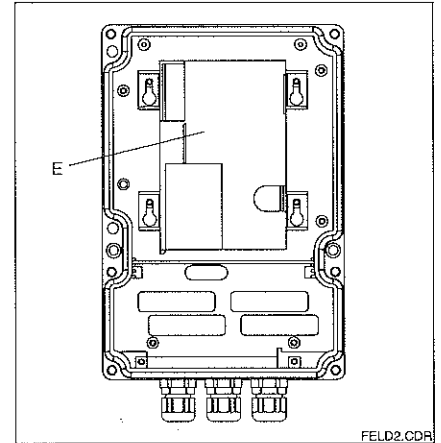

Electrical connection of
Liquisys M CUM 223 /
253

Dimensions

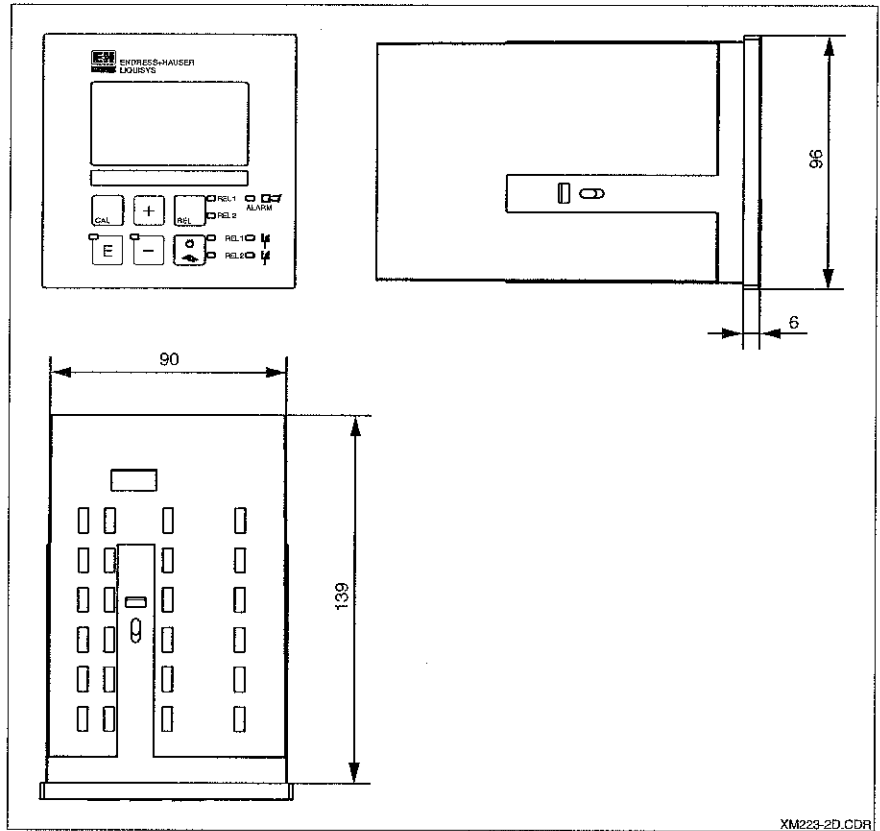

Dimensions of
Liquisys M CUM 223

XM223-2D.CDR

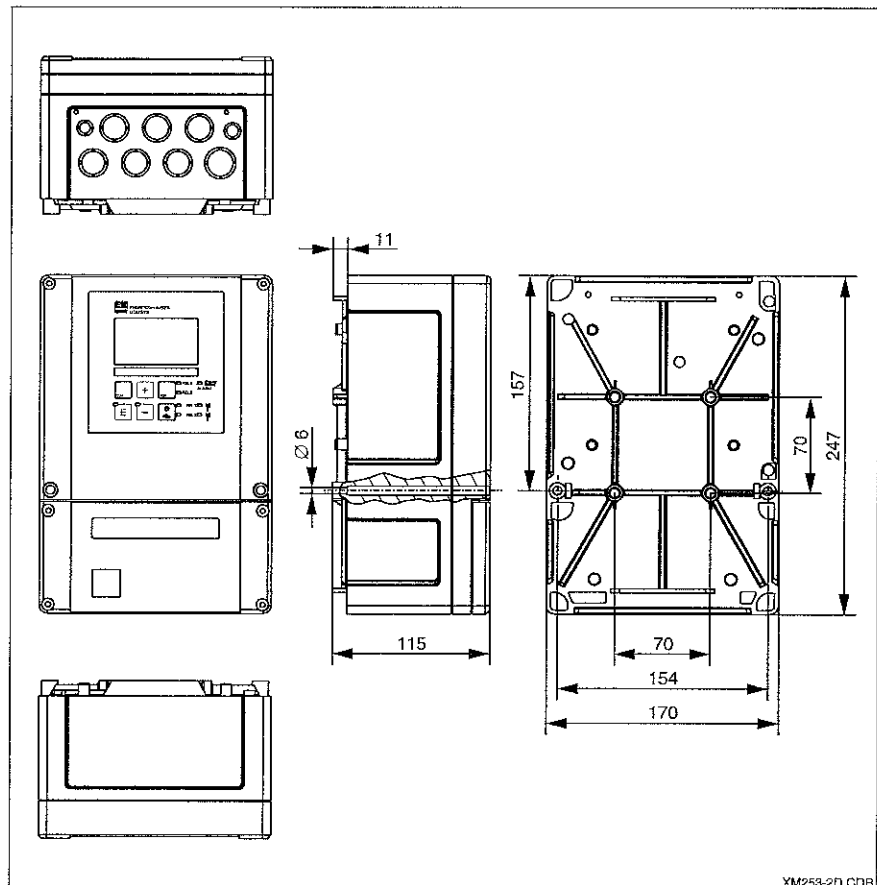

Dimensions of
Liquisys M CUM 253

XM253-2D.CDR

Mounting of Liquisys M CUM 223

The panel-mounted version is mounted using the supplied tensioning screws. The required overall mounting depth is approx. 165 mm.

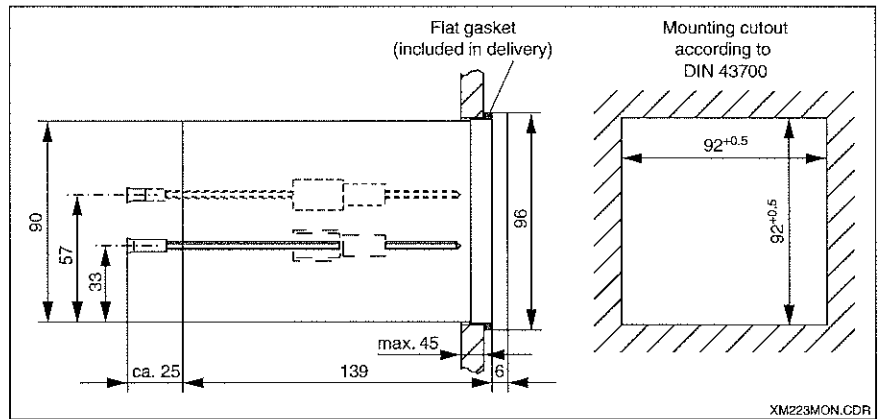

Installation of panel-mounted housing

Mounting of Liquisys M CUM 253

Weather protection cover CYY 101 (see Accessories)

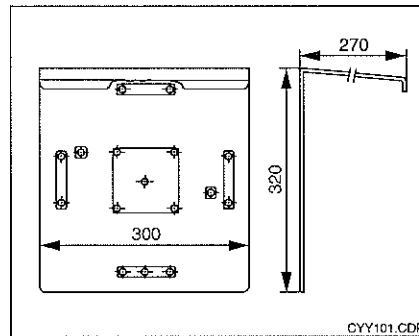

There are several mounting options for the field instrument:

- Mounting on a square-tube mounting post
- Mounting on cylindrical pipes
- Wall mounting with fastening screws

Weather protection cover CYY 101 is required for outdoor installation. This cover is compatible with all field instrument mounting options.

Universal upright post CYY 102 or identical upright post of suspension assembly holder CYH 101 (square tube, see Accessories); mounting of weather protection cover and field instrument

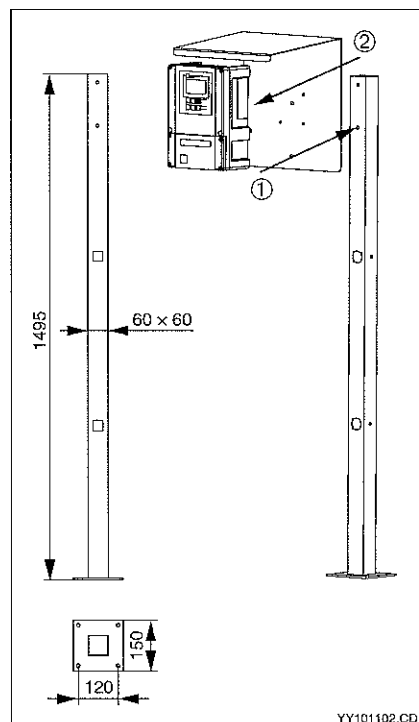

Proceed as follows to install the instrument on a square-tube mounting post (universal upright post CYY 102 or upright post of suspension assembly holder CYH 101):

- ① Install the weather protection cover on the upright post first.
- ② Attach the field instrument to the weather protection cover from the rear.

Mounting of Liquisys M CUM 253 (continued)

Post mounting kit for installation of field housing on cylindrical pipes (horizontal or vertical, max. \varnothing 60 mm; see Accessories)

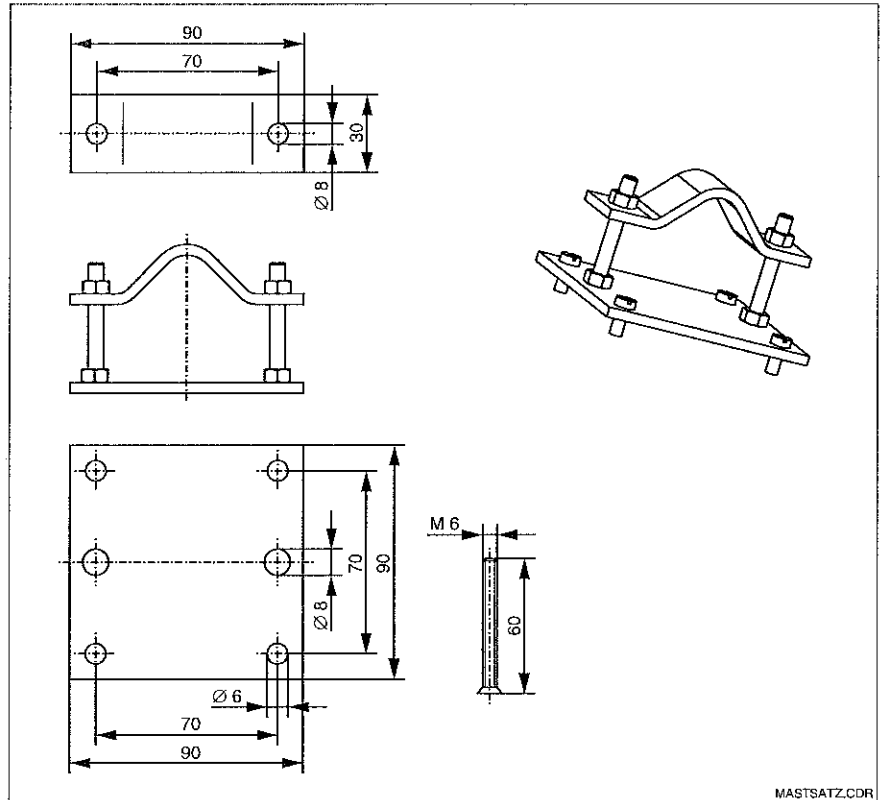

Mounting on cylindrical pipes (shown with weather protection cover installed on right)

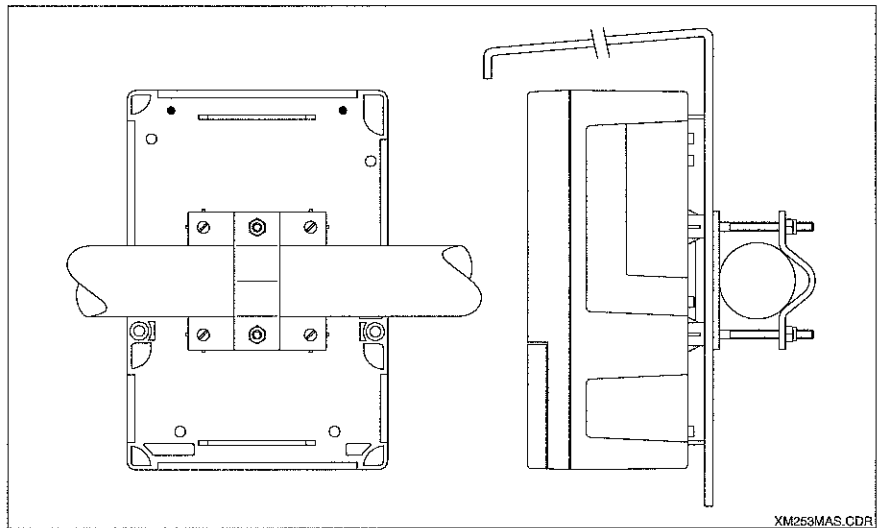

Wall mounting
Screws: \varnothing 6 mm
Anchors: \varnothing 8 mm

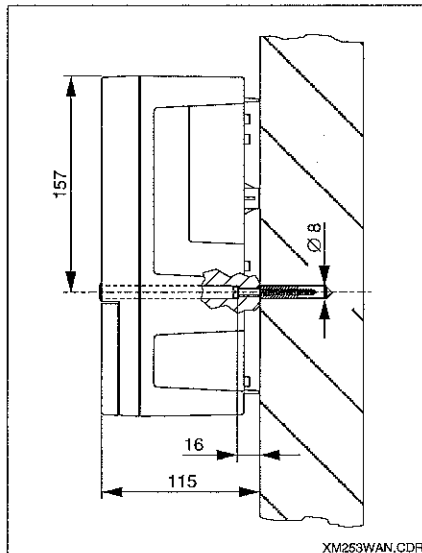

Technical data

General specifications

Manufacturer	Endress+Hauser
Product designation	Liquisys M CUM 223 Liquisys M CUM 253

Operating mode and system design

Measuring principle	A CUS 31 or CUS 41 sensor is connected to the digital sensor interface on the Liquisys M CUM 223 / 253. The sensors supply a standardised signal for turbidity and temperature.
---------------------	---

Input

Measured quantities	turbidity, suspended solids, temperature
---------------------	--

Turbidity measurement with CUS 31

Measuring range	0.000 ... 9999 FNU, 0.00 ... 3000 ppm, 0.0 ... 3.0 g/l, 0.0 ... 200.0%
Turbidity offset range	±99.99 FNU, ±99.99 ppm, ±99.9 g/l, ±99.9%

Suspended solids measurement with CUS 41

Measuring range	0.00 ... 9999 FNU, 0.00 ... 9999 ppm, 0.0 ... 300.0 g/l, 0.0 ... 200.0%
Suspended solids offset range	±99.99 FNU, ±99.99 ppm, ±99.9 g/l, ±99.9%

Temperature measurement

Temperature sensor	NTC, 30 kΩ at 25 °C
Measuring range	-5.0 ... +70.0 °C
Temperature offset range	±5 °C

Signal input for turbidity / suspended solids / temperature

Sensor interface	digital
Max. length of cable to sensor	200 m

Digital inputs 1 and 2

Voltage	10 ... 50 V
Current consumption	max. 10 mA

Output

Signal output for turbidity / suspended solids

Current range	0 / 4 ... 20 mA, galvanically separated; error current 2.4 / 22 mA
Load	max. 500 Ω
Max. resolution	700 digits/mA
Output range	adjustable, min. Δ 0.1 FNU, Δ 1 ppm, Δ 1 g/l, Δ 0.1%
Separation voltage	max. 350 V _{rms} / 500 V DC
Overvoltage (lightning) protection	according to EN 61000-4-5:1995

Signal output for temperature (optional)

Current range	0 / 4 ... 20 mA, galvanically separated
Load	max. 500 Ω
Max. resolution	700 digits/mA
Output range	adjustable, Δ 10 ... Δ 100% of upper range value
Separation voltage	max. 350 V _{rms} / 500 V DC
Overvoltage (lightning) protection	acc. to EN 61000-4-5:1995

Auxiliary voltage output

Output voltage	15 V ± 0.6 V
Output current	max. 10 mA

Contact outputs (potential-free changeover contacts)

Switching current with ohmic load (cos φ = 1)	max. 2 A
Switching current with inductive load (cos φ = 0.4)	max. 2 A
Switching voltage	max. 250 V AC, 30 V DC
Switching power with ohmic load (cos φ = 1)	max. 1250 VA AC, 150 W DC
Switching power with inductive load (cos φ = 0.4)	max. 500 VA AC, 90 W DC

Limit contactor

Pickup / dropout delay	0 ... 7200 s
------------------------	--------------

Technical data (continued)

Output (continued)

Controller

Function (adjustable)	pulse length / pulse frequency controller
Controller response	P, PI, PD, PID
Control gain K_p	0.01 ... 20.00
Integral action time T_i	0.0 ... 999.9 min
Derivative action time T_v	0.0 ... 999.9 min
Period for pulse length controller	0.5 ... 999.9 s
Frequency for pulse frequency controller	60 ... 180 min ⁻¹

Alarm

Function (switchable)	steady / fleeting contact
Alarm threshold adjustment range	turbidity / suspended solids / temperature: complete measuring range
Alarm delay	0 ... 2000 s (min)

Accuracy

Turbidity measurement with CUS 31

Resolution	0.001 FNU, 0.01 ppm, 0.1 g/l, 0.1%
Deviation of indication ¹	±2% of meas. value (min. 0.02 FNU)
Reproducibility ¹	±1% of meas. value (min. 0.01 FNU)
Measurement deviation ¹ , turbidity signal output	1% of current output range (min. 0.02 FNU)

Suspended solids measurement with CUS 41

Resolution	0.01 FNU, 0.01 ppm, 0.1 g/l, 0.1%
Deviation of indication ¹	±2% of meas. value (min. 0.02 FNU)
Reproducibility ¹	±1% of meas. value (min. 0.01 FNU)
Measurement deviation ¹ , suspended solids signal output	1% of current output range (min. 0.02 FNU)

Temperature measurement

Resolution	0.1 °C
Deviation of indication ¹	max. 1.0% of measuring range
Measurement deviation ¹ , temperature signal output	max. 1.25% of current output range

Ambient conditions

Ambient temperature (nominal operating conditions)	-10 ... +55 °C
Ambient temperature (limit operating conditions)	-20 ... +60 °C
Storage and transport temperature	-25 ... +65 °C
Relative humidity (nominal operating conditions)	10 ... 95%, non-condensing
Protection class of panel-mounted unit	IP 54 (front), IP 30 (housing)
Protection class of field housing	IP 65
Electromagnetic compatibility	interference emission and interference immunity acc. to EN 61326-1:1998

Physical data / design

Dimensions of panel-mounted unit (H x W x D)	96 x 96 x 145 mm
Mounting depth	approx. 165 mm
Dimensions of field housing (H x W x D)	247 x 170 x 115 mm
Weight of panel-mounted unit	max. 0.7 kg
Weight with field housing	max. 2.3 kg
Display	LC display, two lines, five and nine digits, with status indicators

Materials

Housing of panel-mounted unit	polycarbonate
Front membrane	polyester, UV-resistant
Field housing	ABS PC Fr

Power requirements

Supply voltage	100 / 115 / 230 V AC +10 / -15%, 48 ... 62 Hz 24 V AC/DC +20 / -15%
Power consumption	max. 7.5 VA
Fuse protection	fine-wire fuse, medium time-lag, 250 V / 3.15 A

¹acc. to IEC 746-1, for nominal operating conditions

Subject to modifications.

Accessories

Mounting accessories

Type	Features	Order number
Weather protection cover CYY 101	For mounting on field housing, for outdoor installation Dimensions (H x W x D): 320 x 300 x 270 mm Material: stainless steel 1.4301	CYY 101-A
Universal upright post CYY 102	Square tube for mounting of field housing Dimensions (H x W x D): 1495 x 60 x 60 mm Material: stainless steel 1.4301	CYY 102-A
Suspension assembly holder CYH 101	For installation on basin or channel rim Materials: stainless steel 1.4301 / PE	CYH 101-D
Pendulum frame	For pendulum suspension of assemblies, e.g. CYA 611 Material: stainless steel 1.4301	50080196
Post mounting kit	Kit for mounting of field housing on horizontal or vertical pipes (Ø max. 60 mm) Material: stainless steel 1.4301	50086842

Assemblies

Type	Features	Applications
DipFit W CYA 611	Immersion assembly with G 1, G ¾ or NPT ¾" thread	Basins and channels
FlowFit W CUA 250	Flow assembly (pressure-resistant up to 6 bar / 20 °C)	Pipelines
CUA 461	Retractable assembly for sensor installation and removal without process interruption (max. 2 bar)	Pipelines

Sensors

Type	Features	Applications
TurbiMax W CUS 31	Turbidity sensor for drinking water and service water applications	Drinking water, filter monitoring, phase separation, surface water
TurbiMax W CUS 41	Sensor for measurement of suspended solids	Sedimentation, sewage treatment plants, industrial service water, phase separation

Cable / junction box

Type	Features	Order number
CYK 8	Data cable (unassembled) for extension of CUS 31 / CUS 41 sensor connection cables	50089633
VBM	Junction box	50003987

Product structure

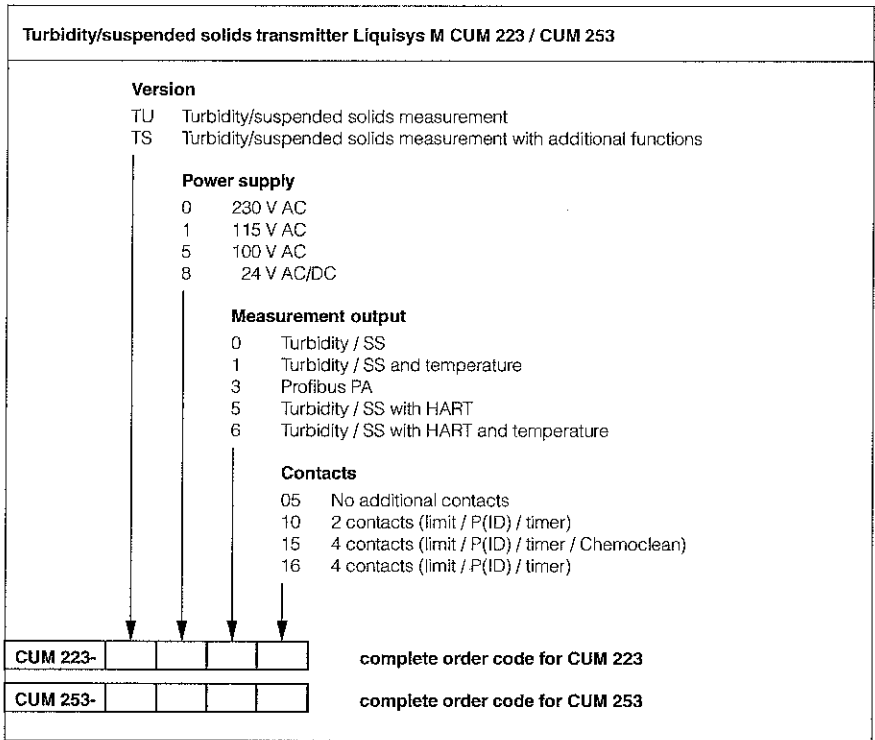

Endress+Hauser GmbH+Co.
- Instruments International -
 P.O. Box 22 22
 D-79574 Weil am Rhein
 Tel. (07621) 975 - 02
 Fax (07621) 975345

Endress + Hauser
 Nothing beats know-how





Level



Pressure



Flow



Temperature



Liquid
Analysis



Registration



Systems
Components



Services



Solutions

Technical Information

Turbimax CUS31

Turbidity sensor

Installation and immersion sensor for drinking water and industrial water according to the 90° scattered light method

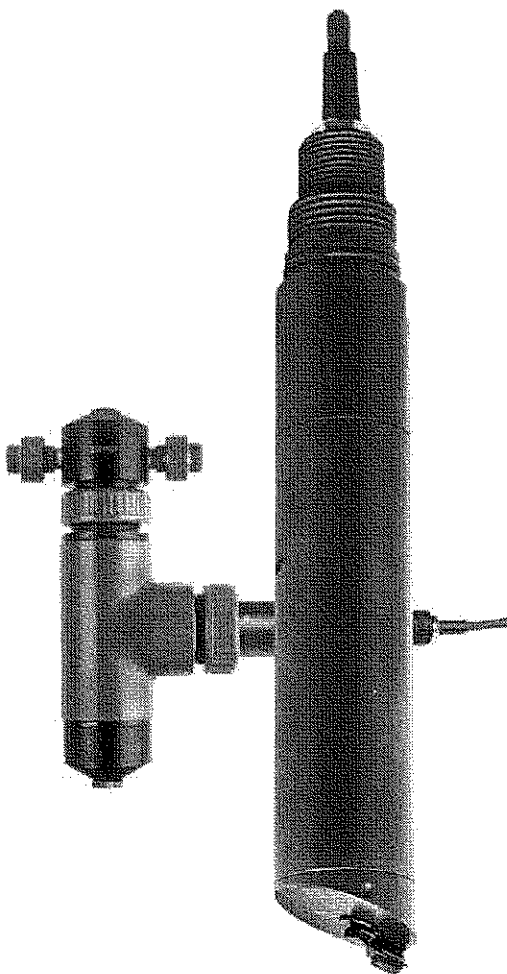

Application

- All phases of drinking water processing
- Coagulation and flocculation
- Filter rupture monitoring
- Filter backwash
- Control of clear rinsing cycles
- Monitoring of phase separation processes
- Boiler feedwater
- Monitoring of cooling water
- Monitoring of surface waters
- Outlet monitoring of sewage treatment plants
- Monitoring of industrial water discharge
- Recycling of industrial water

Your benefits

- All-purpose:
 - Direct installation in water pipes
 - Suitable as a drinking water sensor for every installation with a wall distance greater than 8 cm (3")
 - Measurement under pressure to avoid degassing
 - Integrated temperature measurement
 - Permissible distance between sensor and transmitter: 200 m (660 ft)
- Standardized and simple:
 - Measurement according to EN 27027 / ISO 7027
 - Commissioning without formazine
 - Factory calibration ("plug and play")
- Cost saving and safe:
 - Inclined plain sensor surface uses medium flow to increase the self-cleaning effect and repels air bubbles
 - Wiper unit can be retrofitted
 - Self-monitoring and plausibility check
 - Scratch-resistant sapphire glass measuring window

Function and system design

Measuring principle

Turbidity measurement

For turbidity measurement a light beam is sent through the medium and is diverted from its original direction by optically denser particles, e.g. solid matter particles.

Function

Nephelometric measuring principle 90° NIR scattered light according to EN 27027

The 90° scattered light method with a wavelength in the near-infrared range (880 nm) according to ISO 7027 / EN 27027 records turbidity values under standardized, comparable conditions. A temperature signal is also recorded and transmitted in addition to the turbidity signal. The excitation radiation of an infrared transmitter (→ , item 1) strikes the medium at a defined angle of beam. The different refractions of light between the entrance window and the medium (water) are taken into account. Particles in the medium (item 5) create a scattered radiation which strikes the scattered light receivers (items 3, 4) at a defined angle of beam. The measurement in the medium is constantly compared with the values of a reference receiver (item 2). Digital filter functions with excellent interference signal suppression and sensor self-monitoring ensure additional measurement reliability.

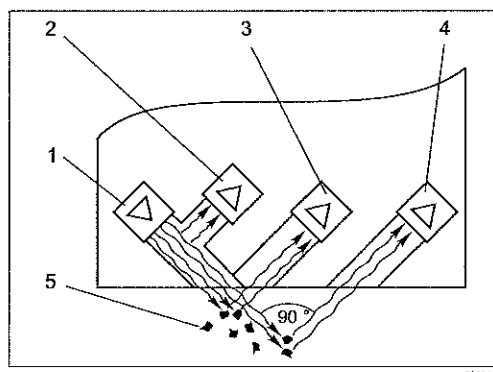

- 1 Infrared sender
- 2 Reference diode
- 3 Scattered light receiver 1
- 4 Scattered light receiver 2
- 5 Particle

Turbidity measurement acc. to ISO 7027 / EN 27027

Measuring system

A complete measuring system comprises:

- Turbidity sensor CUS31
- Transmitter, e.g. Liquisys M CUM253
- Assembly:
 - Flow assembly E or S (each with installed, factory calibrated sensor) or
 - Immersion assembly, e.g. Dipfit W CYA611 or
 - Retractable assembly, e.g. Cleanfit W CUA451

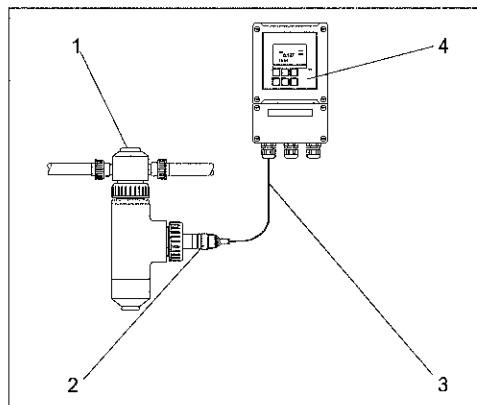

Measuring system with flow assembly

- 1 Flow assembly S
- 2 CUS31-**S
- 3 Sensor cable
- 4 Transmitter Liquisys M CUM253

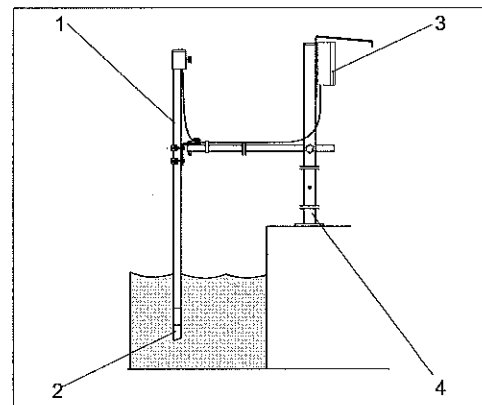

Measuring system with immersion assembly

- 1 Immersion assembly Dipfit W CYA611
- 2 CUS31-**A
- 3 Transmitter Liquisys M CUM253 (with weather protection cover CYY101)
- 4 Universal assembly holder CYH101

Input

Measured variable	Turbidity
Measuring range	0.000 to 9999 FNU 0.00 to 3000 ppm 0.0 to 3.0 g/l 0.0 to 200 %

Power supply

Electrical connection The sensor is connected to the transmitter by means of a multi-core, shielded measuring cable (fixed cable at the sensor). To extend the measuring cable, a VBM or RM junction box and a CYK81 extension cable must be used.

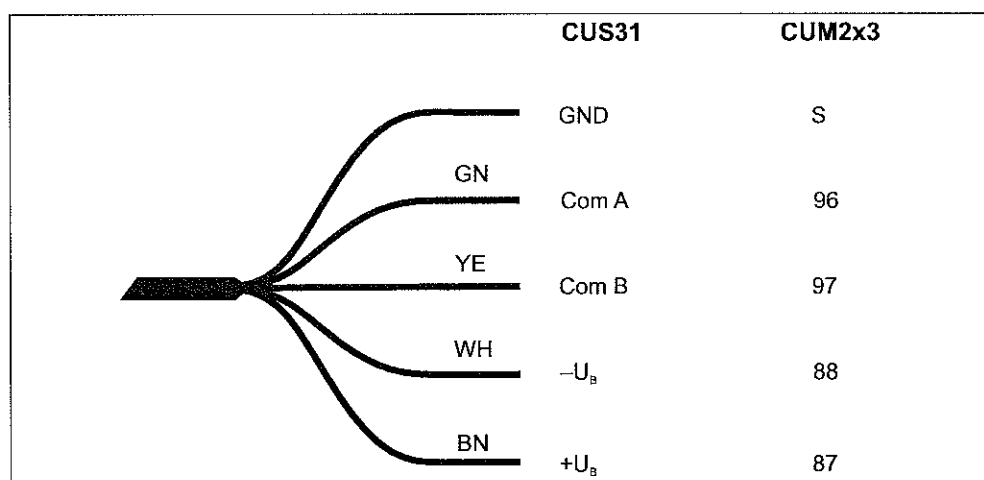

Measuring cable (fixed cable) resp. extension cable (CYK81)



Note! Please pay special attention to the instructions on sensor connection in the Operating Instructions of the transmitter.

Performance characteristics

Maximum measured error	< 5 % (min. 0.02 FNU) of measured value (system measured error related to the primary formazine standard / tracing according to ISO 5725 and ISO 7027 / EN 27027)
Repeatability	< 1 % (min. 0.01 FNU) of measured value
Wavelength	880 nm
Factory calibration	traceable to formazine standard and SiO ₂

Installation

Wall distance

Installing the sensor in pipework or very close to the wall can cause backscatter which results in a higher sensor signal.

The effective wall or bottom distance can be optimized by aligning the flat sensor side.

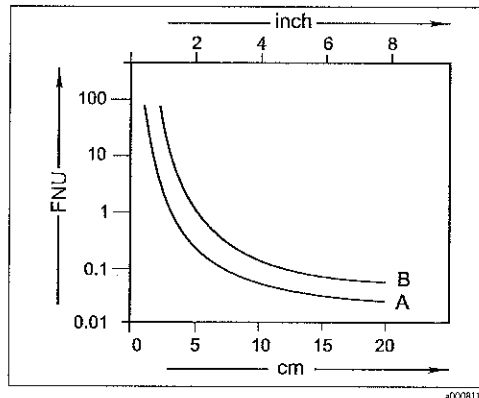

Effect of the distance from the wall or bottom

A Dark wall or bottom (non-reflective)

B Bright wall or bottom (reflective)



Note!

The following generally applies: The lower the turbidity to be measured, the darker the vessel walls should be and the greater the wall distance should also be.

When measuring in drinking water, the wall distance to a dark wall must be **at least 8 cm (3")**. Bright pipes are not suitable for the drinking water sector.

Pipe installation

The following figure illustrates various installation positions in pipes and indicates whether they are permitted or not.

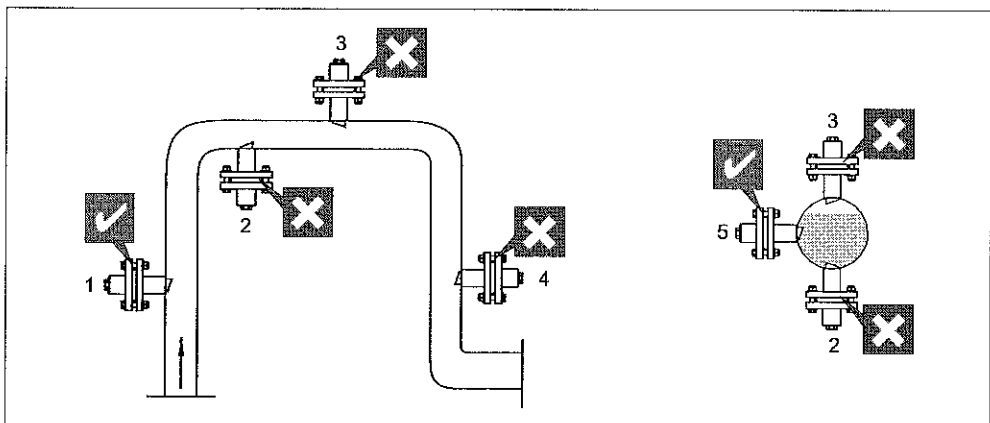

Orientation and installation positions (with adapter CUA120-A/B resp. retractable assembly CUA451)

- The pipeline diameter must be at least 100 mm (4") if reflective materials (e.g. stainless steel) are used.
- Install the sensor in places with uniform flow conditions.
- Orientate the sensor surface against the medium flow (self-cleaning effect).
- The best installation location is in the ascending pipe (→ , it. 1). Installation is also possible in the horizontal pipe (it. 5).
- Do not install the sensor in places where air may collect or foam bubbles form (it. 3) or where suspended particles may settle (it. 2).
- Avoid installation in the down pipe (it. 4).

Flow operation

In general

- Install the flow assembly as vertical as possible so that the medium flows to the sensor from below.
- Two sensor orientations are possible for every installation:
 - Parallel to the medium flow
Orientation parallel to the medium flow is required when using the CUR 3 spray head.
 - Against the medium flow
Orientation against the medium flow is used to increase the self-cleaning effect in heavily-soiled media (> 15 FNU). The wall reflection is negligible here due to the high absorption.

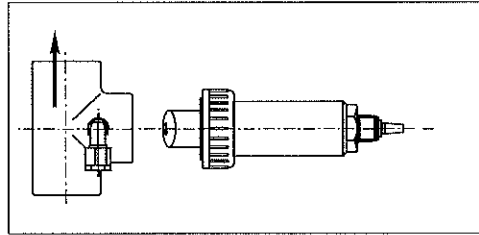

Parallel to the medium flow

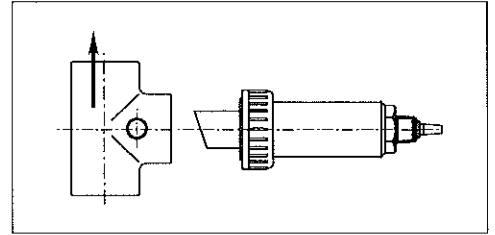

Against the medium flow



Note!

For turbidities < 5 FNU, use the sensor versions CUS31-**E or CUS31-**S.

Flow operation in the drinking water sector (with special calibration)

When the sensor is ordered with assembly E or S, the sensor is **individually calibrated** in the factory with the assembly ordered.

Therefore, no initial calibration on site is necessary.

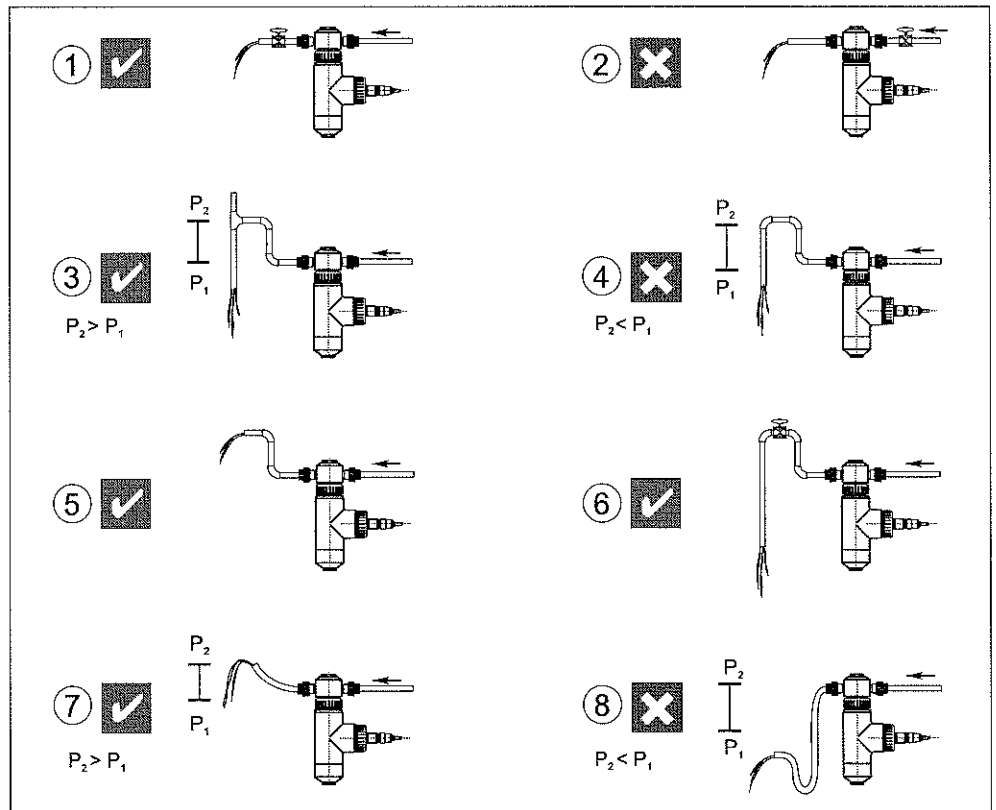

Installation situations with flow assembly E resp. S

1. Correct: pressure reduction after measurement
Degassing is avoided. The gas in the water remains dissolved.
2. Incorrect: Pressure reduction before measurement
The pressure reduction creates favourable conditions for gas bubble formation.

3. Correct: Outlet of the assembly raised and vented
Gas cannot collect in the upper section of the assembly. The outlet pipe is vented at the highest point. A slight overpressure forms in the assembly as a result of the height difference of the raised outlet.
4. Incorrect: Outlet raised but not vented
A low pressure forms in the assembly if venting via the downcomer outlet pipe does not take place due to too small a cross-section.
5. Correct: Standard application in event of little initial pressure
Slight overpressure due to raised outlet level, no gas collecting in the upper section of the assembly.
6. Limited application: The valve reduces the volume flow
 **Note!**
The outlet line may not be too thin or too long as otherwise a low pressure forms in the assembly. A vent for the drain line must be present. The outlet must be completely opened at regular intervals as otherwise the raising of the outlet level would not make any sense.
If using a tube as the drain line, avoid formation of siphon draw (low points in the tube)! Otherwise venting does not take place.
7. Correct: Tube as outlet line
Must be raised!
8. Incorrect: Tube not raised
A low pressure forms in the assembly which favours gas bubble formation. In addition, low points in the tube result in siphon draw and thereby prevent venting. This results in pressure changes in the assembly.

Gas bubble elimination

Conventional turbidity measurements are carried out in an unpressurised sample. When the pressure on a sample (which was pressurised beforehand) is released, fine bubbles are produced which distort the turbidity measurement.

There are several methods of eliminating these gas bubbles:

- Pressurized measurement in the bypass (pressure is not released until after the measurement).
- For measurements without overpressure or with slight overpressure:
Free medium flow above the assembly level. The mounting location should be as low as possible to take advantage of the maximum possible pressure.
- Unpressurized measurement and gas bubble elimination using wiper cleaning.
The wiping duration and interval can be programmed for optimum results.
- Reduction of the flow to the lowest possible value (50 l/h).
Slight flow prolongs the period in which the medium is in the assembly. This means that gas bubbles have more time to rise to the top. The sensor response time increases slightly due to the lower flow.
- Flow assembly S with integrated gas bubble trap (CUS31-**S)
Most of the gas bubbles are sent directly to the assembly outlet in the upper half of the separated inlet (7). The other half of the medium flows into a ring channel (1) by means of the central pipe. The remaining bubbles rise here and are conveyed out of the measuring chamber by means of holes in the outlet (2) located in the centre of the assembly. Bubble-free medium (3) is pushed down into the measuring chamber (5). This also leads to a high flow which results in a quick response time. In addition, this almost completely prevents dirt particles settling.

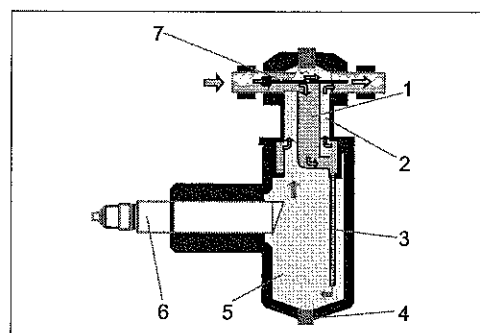

- 1 Ring channel
- 2 Outlet
- 3 Bubble-free medium
- 4 Drain screw (G1 thread)
- 5 Measuring chamber
- 6 Sensor CUS31
- 7 Separated inlet

Flow assembly S with gas bubble trap

3000842

Immersion operation

When installing the sensor in immersion assemblies, please ensure that a sufficient wall distance is observed during operation.

- For this reason, select an installation location in which a **minimum wall distance of 150 mm (6")** is observed even with varying levels or altered flow profiles.
Mounting in a suspended assembly with chain must therefore be avoided.
- The sensor must immerse at least 40 mm (1.5") into the medium.

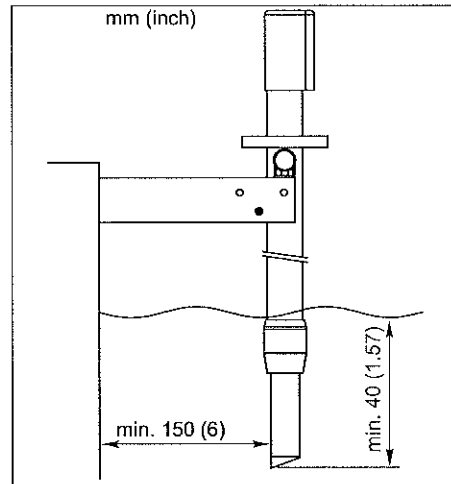

CYA611 with pendulum frame

Environment

Storage temperature -20 to 60 °C (0 to 140 °F)

Ingress protection IP 68

Mechanical construction

Dimensions

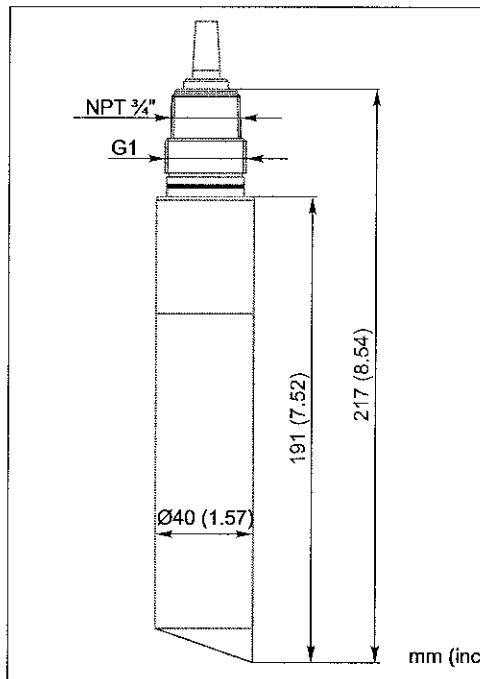

CUS31

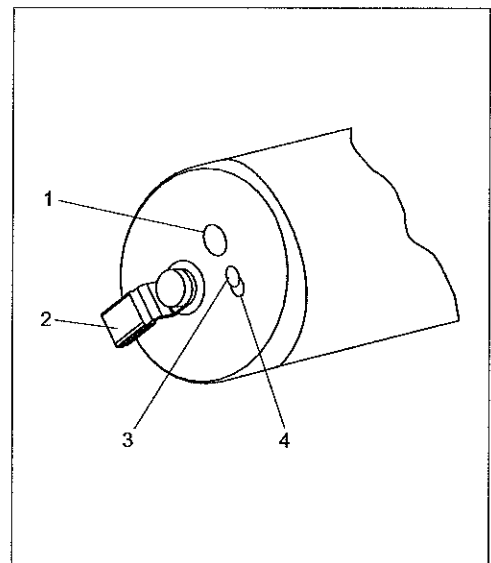

Sensor optics

- 1 Photodiode (receiver)
- 2 Wiper (optional)
- 3 Photodiode (receiver)
- 4 LED (IR transmitter)

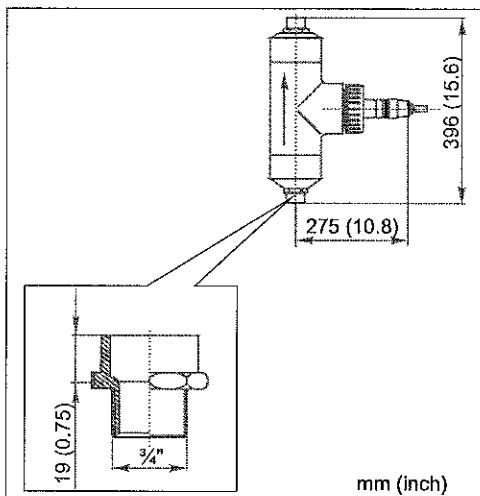

CUS31-**E (with assembly E)

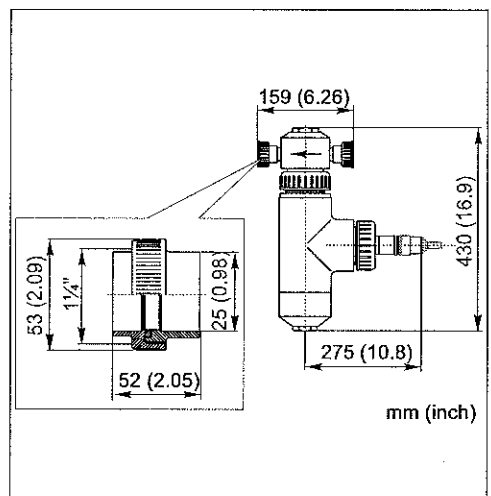

CUS31-**S (with assembly S)

Weight

with cable length 7 m (23 ft): 0.7 kg (1.5 lbs.)
with cable length 15 m (49 ft): 1.1 kg (2.4 lbs.)

Material

Sensor carrier plate, shaft	PVC / PPS GF 40 (polyphenylene sulfide with 40% glass-fibre)
Optical windows	Sapphire
Flow assemblies E and S	PE
Wiper (CUS31-W** only)	Rubber
Cable	TPEO (polyolefine based elastomer), -40 to 130 °C (-40 to 260 °F)

Process connection

G1 and NPT 3/4"

Temperature sensor

NTC resistor 30K at 25 °C (77 °F)

Ordering information

Product structure

Sensor	
A	Standard sensor
W	Sensor with integr. wiper
Cable length	
2	Connecting cable 7 m (23 ft)
4	Connecting cable 15 m (49 ft)
9	Special cable length
Assembly	
A	Without assembly
E	Assembly for bubblefree media
S	Assembly with integr. debubbling system
CUS31-	complete order code

Scope of delivery

The scope of delivery comprises:

- Turbidity sensor acc. to the version:
 - CUS31-**A
factory-calibrated sensor, without assembly
 - CUS31-**E
installed and factory-calibrated in assembly for bubble-free media, with fixing bracket
 - CUS31-**S
installed and factory-calibrated in assembly with gas bubble trap, with fixing bracket
- Operating Instructions BA176C/07/en

Certificates, approvals

Quality certificate

Each sensor has an individual quality certificate with information on the sensor identification and calibration according to ISO 7027 / EN 27027.

Accessories

Connection accessories

CYK81 measuring cable

- Non-terminated measuring cable for extension of sensor cables of e.g. Memosens sensors, CUS31/CUS41
- 2 wires, twisted pair with shield and PVC-sheath (2 x 2 x 0.5 mm² + shield)
- Sold by the meter, order no. 51502543

Junction box VBM

- For cable extension
- 10 terminals
- Cable entries: 2 x Pg 13.5 or 2 x NPT 1/2"
- Material: aluminum
- Ingress protection: IP 65 (≅ NEMA 4X)
- Order numbers:
 - cable entries Pg 13.5: 50003987
 - cable entries NPT 1/2": 51500177

Junction box RM

- For cable extension (e.g. for Memosens sensors or CUS31/CUS41)
- 5 terminals
- Cable entries: 2 x Pg 13.5
- Material: PC
- Ingress protection: IP 65 (≅ NEMA 4X)
- Order no.: 51500832

Installation accessories	<p>Immersion assembly holder CYH101</p> <ul style="list-style-type: none"> ■ For pH, ORP, oxygen, conductivity assemblies and for oxygen and turbidity sensors; ■ Ordering acc. to product structure (Technical Information TI092C/07/en) <p>Immersion assembly Dipfit W CYA611</p> <ul style="list-style-type: none"> ■ For sensor immersion in basins, open channels and tanks, PVC ■ Ordering acc. to product structure, see Technical Information TI166C/07/en <p>Flange adapter CUA120</p> <ul style="list-style-type: none"> ■ for CUS31/CUS41 ■ Ordering information: <ul style="list-style-type: none"> – CUA120-A for welding flange, h=47 mm (1.85") – CUA120-B for welding flange, h=93 mm (3.66") <p>Flow assembly Flowfit CUA250</p> <ul style="list-style-type: none"> ■ for CUS31/CUS41 ■ ordering acc. to product structure (Technical Information TI096C/07/en) <p>Retractable assembly Cleanfit CUA451</p> <ul style="list-style-type: none"> ■ retractable assembly with ball valve; for turbidity sensors; material: stainless steel ■ ordering acc. to product structure (Technical Information TI369C/07/en) <p>Welding rinse socket DN 65</p> <ul style="list-style-type: none"> ■ order no. 51500912 <p>Welding rinse socket DN 50 / PN 16</p> <ul style="list-style-type: none"> ■ order no. 55001306
Transmitter	<p>Liquisys M CUM 223/253</p> <ul style="list-style-type: none"> ■ Turbidity transmitter ■ Panel mounting or field housing ■ Optional with Hart® or Profibus communication ■ Ordering acc. to product structure, see Technical Information TI200C/07/en
Cleaning	<p>Chemoclean</p> <ul style="list-style-type: none"> ■ Injector CYR10 and program sequencer CYR20 ■ Ordering acc. to product structure, see Technical Information (TI046C/07/en) <p>Chemoclean CUR3</p> <ul style="list-style-type: none"> ■ Spray head for flow assemblies CUA250 and COA250 ■ order no. CUR3-1
Monitoring, service kit, recalibration	<p>CUY22</p> <ul style="list-style-type: none"> ■ Check unit for CUS31 for checking the sensor ■ order no. 51504477 <p>Service kit CUY31</p> <ul style="list-style-type: none"> ■ 3 spare wiper arms ■ order no. 50089252 <p>Recalibration CUS31</p> <ul style="list-style-type: none"> ■ Calibration as per ISO 7027 / EN 27027 ■ order no. 50081264

Instruments International

Endress+Hauser
Instruments International AG
Kaegenstrasse 2
4153 Reinach
Switzerland

Tel.+41 61 715 81 00
Fax+41 61 715 25 00
www.endress.com
info@ii.endress.com

Endress+Hauser 
People for Process Automation

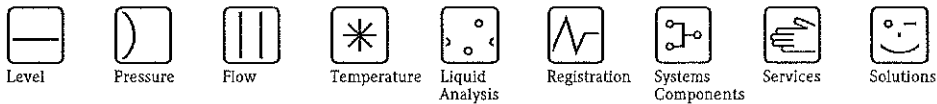

Technical Information

Ecograph T

Multi Channel Recorder RSG30
Display, record, communicate

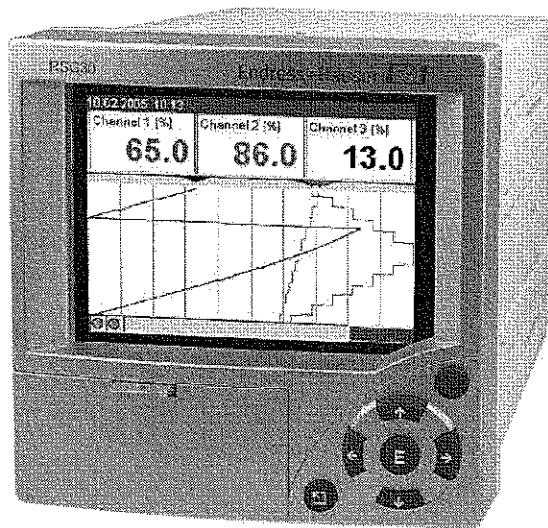

Applications

The instrument can be used in many processes and industries:

- Quality and quantity monitoring in the water/wastewater industry
- Monitoring of processes in power stations
- Food and dairy industry processes
- Displaying and recording critical parameters in production cycles
- Tank and level monitoring
- Temperature monitoring in metal working
- Cold storage and transportation monitoring



Your benefits

- Informative: interim, daily, monthly and yearly analysis; counters, operation time and quantities; min-, max- and average value recording
- Versatile: up to 6 universal inputs record all measuring signals
- Clear layout: multi-coloured display, digital, bargraph and curve display
- Compact: low installation depth, saves space and money

- Safe: reliable data archiving with internal memory and separate CompactFlash card (mechanically locked). No data loss even in event of power failure!
- System-enabled: network integration and remote data transmission via Ethernet, RS232/RS485 (modem) and USB
- Available worldwide: integrated Web server function for remote monitoring e.g. with E+H Fieldgate Viewer®
- Intelligent: calculations by mathematic functions
- Reliable: inputs are galvanically isolated from the system
- Complete: ReadWin® 2000 PC software package contained in scope of supply for professional, tamper-proof data processing
- Flexible: direct access to archived data also with MS® Excel or in ReadWin® 2000 for example

Function and system design

Measuring principle

Electronic acquisition, display, recording, analysis, remote transmission and archiving of analog and digital input signals.

Measuring system

Multi-channel data recording system with multi-coloured LCD display (120 mm / 4.7" screen size), galvanically isolated universal inputs (U, I, TC, RTD), digital input, transmitter power supply, limit relay, communication interfaces (USB, Ethernet, RS232/485), internal Flash memory and CompactFlash card. 100 ms scan rate for all channels. ReadWin® 2000 PC software for comprehensive offline device configuration and data analysis.

Block diagram

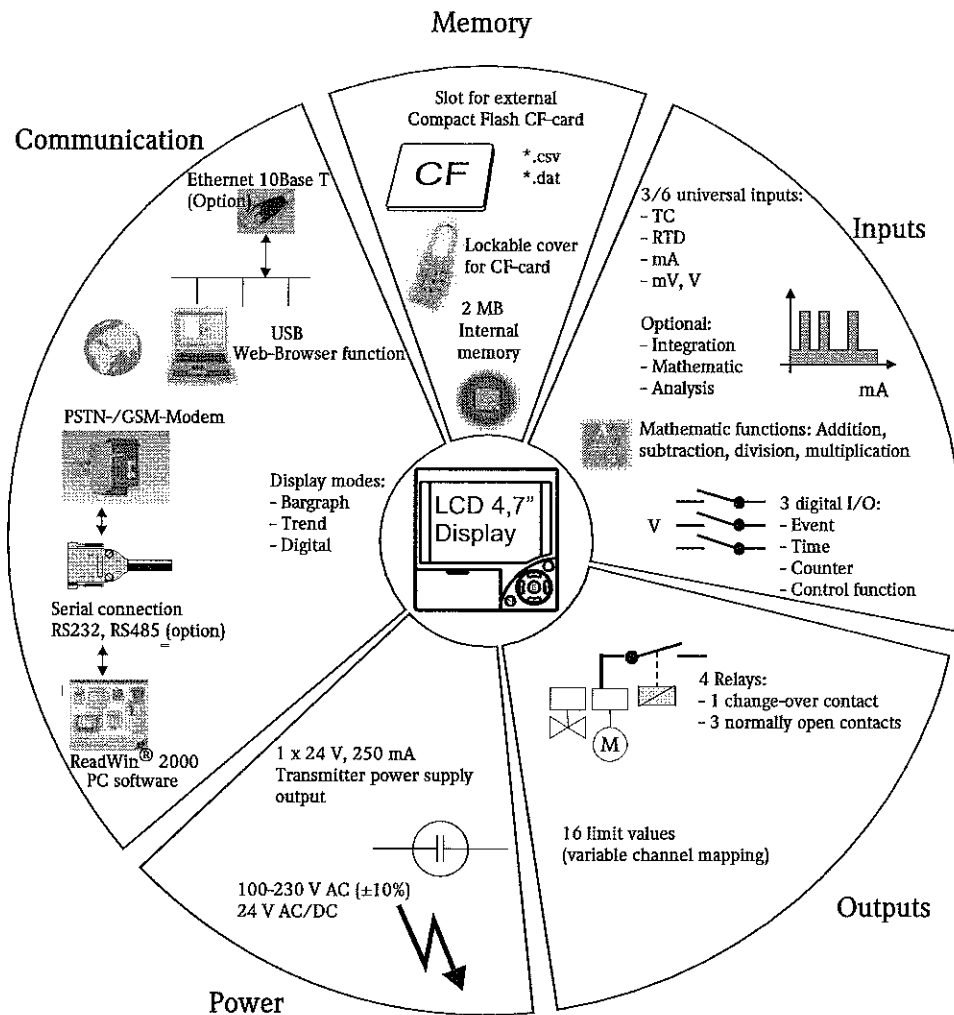

This block diagram is only indicative of the functionality.

Input

Analog multi-function input channel 1-6

Measured variable, measuring range

To IEC 60873-1:

An additional display error of $-/+ 1$ digit is permitted for every measured value.

Measuring ranges which can be selected per channel:

Measured variable	Measuring range	Maximum measured error of measuring range (oMR)	Input impedance
Current	0...20 mA 0...5 mA 4...20 mA Overrange: up to 22 mA	± 0.10 %	Load: = 50 Ohm
Voltage > 1 V	0...10 V 0...5 V 1...5 V ± 10 V ± 30 V	± 0.10 %	= 980 kOhm
Voltage ≤ 1 V	0...1 V ± 1 V ± 150 mV	± 0.10 %	= 2.7 MOhm
Resistance thermometer (RTD)	Pt100: -200 to 850 °C (-328 to 1562 °F) (IEC751, JIS1604, GOST) Pt500: -200 to 850 °C (-328 to 1562 °F) (IEC751, JIS1604) Pt1000: -200 to 600 °C (-328 to 1112 °F) (IEC751, JIS1604)	4-wire: ± 0.10 % oMR 3-wire: ± (0.10 % oMR + 0.8 K) 2-wire: ± (0.10 % oMR + 1.5 K)	
	Cu100: -200 to 200 °C (-328 to 392 °F) (GOST) Cu50: -200 to 200 °C (-328 to 392 °F) (GOST) Pt50: -200 to 850 °C (-328 to 1562 °F) (GOST)	4-wire: ± 0.20 % oMR 3-wire: ± (0.20 % oMR + 0.8 K) 2-wire: ± (0.20 % oMR + 1.5 K)	
	Cu53: -50...180 °C (-58 bis 356 °F) (GOST) Pt46: -200 to 650 °C (-328 to 1202 °F) (GOST)	4-wire: ± 0.30 % oMR 3-wire: ± (0.30 % oMR + 0.8 K) 2-wire: ± (0.30 % oMR + 1.5 K)	
Thermocouples (TC)	Type J (Fe-CuNi): -210 to 999.9 °C (-346 to 1832 °F) (IEC581-1) Type K (NiCr-Ni): -200 to 1372 °C (-328 to 2501.6 °F) (IEC581-1) Type T (Cu-CuNi): -270 to 400 °C (-454 to 752 °F) (IEC581-1) Type N (NiCrSi-NiSi): -270 to 1300 °C (-454 to 2372 °F) (IEC581-1) Type L (Fe-CuNi): -200 to 900 °C (-328 to 1652 °F) (DIN43710, GOST)	± 0.10 % oMR from -100 °C (-148 °F) ± 0.10 % oMR from -130 °C (-202 °F) ± 0.10 % oMR from -200 °C (-328 °F) ± 0.10 % oMR from -100 °C (-148 °F) ± 0.10 % oMR from -100 °C (-148 °F)	= 2.7 MOhm
	Type D (W3Re-W25Re): 0 to 2315 °C (32 to 4199 °F) (ASTME998) Type C (W5Re-W26Re): 0 to 2315 °C (32 to 4199 °F) (ASTME998) Type B (Pt30Rh-Pt6Rh): 0 to 1820 °C (32 to 3308 °F) (IEC581-1) Type S (Pt10Rh-Pt): 0 to 1768 °C (32 to 3214 °F) (IEC581-1) Type R (Pt13Rh-Pt): -50 to 1768 °C (-58 to 3214 °F) (IEC581-1)	± 0.15 % oMR from 500 °C (932 °F) ± 0.15 % oMR from 500 °C (932 °F) ± 0.15 % oMR from 600 °C (1112 °F) ± 0.15 % oMR from 100 °C (212 °F) ± 0.15 % oMR from 100 °C (212 °F)	= 2.7 MOhm

Limit values

Limit values for input voltage and current as well as cable open circuit detection/line influence/temperature compensation

Measured variable	Limit values (steady-state, without destroying input)	Cable open circuit detection/line influence/temperature compensation
Current	Maximum permitted input voltage: 2.5 V Maximum permitted input current: 50 mA	4...20 mA range with cable open circuit monitoring to NAMUR NE43. Activate/deactivate the 4...20 mA loop monitoring as per NAMUR recommendation NE43. On activation: ≤ 3.8 mA: Under range (indicate: vvvvvv) ≥ 20.5 mA: Over range (indicate: ^^^^^^) ≤ 3.6 mA or ≥ 21.0 mA: Open Circuit (indicate: ---)
Voltage > 1 V	Maximum permitted input voltage: 35 V	1...5 V range with cable open circuit monitoring: < 0.8 V or > 5.2 V: Open Circuit (indicate: ---)
Voltage ≤ 1 V	Maximum permitted input voltage: 12 V	

Measured variable	Limit values (steady-state, without destroying input)	Cable open circuit detection/line influence/temperature compensation
Resistance thermometer (RTD)	Measuring current: ≤ 1 mA	Disengageable cable open circuit detection Maximum barrier resistance (or line resistance): Max. 200 Ohm (4-wire) Max. 40 Ohm (3-wire) Maximum influence of barrier resistance (or line resistance) for Pt100, Pt500 and Pt1000: 4-wire: $\pm 0.0002\%/Ohm$, 3-wire: $\pm 0.002\%/Ohm$ Maximum influence of barrier resistance (or line resistance) for Pt46, Pt50, Cu100, Cu50 and Cu53: 4-wire: $\pm 0.0006\%/Ohm$, 3-wire: $\pm 0.006\%/Ohm$
Thermocouples (TC)	Maximum permitted input voltage: 12 V	Disengageable cable open circuit detection from 50 kOhm Error, internal temperature compensation: ≤ 2 K

Channel isolation

All analog inputs are galvanically isolated from one another. The testing voltage between the channels is 500 V (no safety isolation)

Scan rate

All channels are scanned within 100 ms.

Resolution

For all ranges: ≥ 18 bit

Integration, analysis, mathematic (option package)

Integration (Quantity calculation of analog channels): It is possible to calculate an intermediate, daily, monthly, yearly or total value (13-digit, 64 bit).

Analysis: Quantity-/operating time recording (standard function), additionally a min/max/average value evaluation within the preset period.

Mathematic: Up to 5 mathematics channels. Mathematic calculation of analog channels using basic arithmetic operands (+, -, *, /), constants. In addition either the sum or the average value of several channels can be calculated. If the mathematics channel is used then 1 analog channel is lost.

Digital inputs**Number**

3 digital inputs

Input level

To IEC 61131-2:

Logical "0" (corresponds to -3 to +5 V), activation with logical "1" (corresponds to +12 to +30 V)

Input frequency

Max. 25 Hz

Pulse length

Min. 20 ms

Input current

Max. 2 mA

Input voltage

Max. 32 V (steady-state, without destroying input)

Selectable functions

Control input, ON/OFF message, pulse counter (13-digit, 64 bit), operating time, message+operating time.
Functions of the control input: start recording, rear illumination OFF, setup lock, time synchronization.

Output

Auxiliary voltage output

The auxiliary voltage is provided to activate the digital input (or sensors) with floating contacts and is galvanically isolated from the system and the inputs (testing voltage 500 V). The ground of the auxiliary voltage and the ground of the digital input are electrically interconnected.

Output voltage:

Approx. 24 V, max. 28 V

Output current:

Maximum 250 mA, short-circuit proof, not stabilised

Relay outputs

Alarm relay:

1 Alarm relay with changeover contact

Standard relay:

3 relays with NO contact for limit value messages (can be configured as NC contact).



Note!

It is not permitted to mix low voltage and safety extra low voltage (do not mix SELV circuits and low voltage).

Response time:

≤ 1 s

Maximum DC contact load:

50 V / 300 mA (steady-state, without destroying input)

Maximum AC contact load:

230 V / 3 A (steady-state, without destroying input)

Power supply / terminal diagram

Electrical connection (wiring diagram)

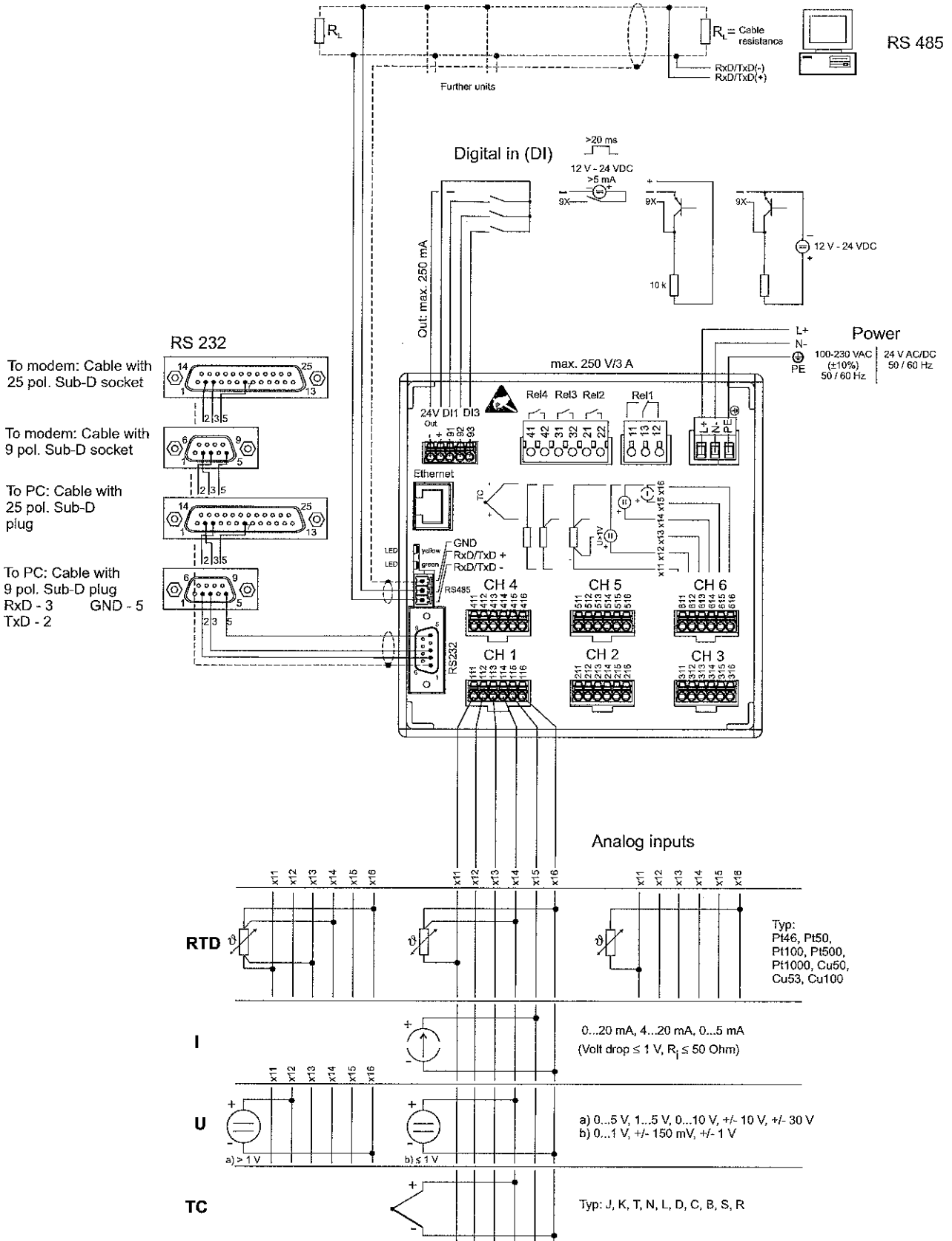

Supply voltage	Low voltage power supply: 100...230 V _{AC} (±10%) Extra-low voltage power supply: 24 V _{AC/DC}
Frequency	Nominal frequency: 50 / 60 Hz
Cable specification	Screw or spring terminal blocks with reverse polarity protection: Digital I/O wire cross-section, RS485 and analog inputs: max. 1.5 mm ² (14 AWG) (spring terminals) Power wire cross-section: max. 2.5 mm ² (13 AWG) (screw terminals) Relay wire cross-section: max. 2.5 mm ² (13 AWG) (spring terminals)
Power consumption	100...230 V: max. 30 VA 24 V: max. 24 VA
Connection data interface, communication	<p>USB port (standard):</p> <p>Front-mounted USB-B socket (V1.1) for connecting a laptop or computer using a shielded USB cable. The USB port can be used for program transmission and unit configuration (printers or modems cannot be connected here).</p> <p>Ethernet interface (option):</p> <p>Rear-mounted Ethernet interface 10BaseT, plug type RJ45, connection via shielded cable, allocation of IP address via setup menu in unit. The unit can be connected to units in an office environment with this interface. For safe spacing distances, observe the office equipment standard IEC 60950-1. Direct connection to a PC is possible with a "crossover" cable. The unit can be used in the network as a "Web server". Two Ethernet function LEDs on the rear of the unit.</p> <p>Serial RS232/RS485 interface (option):</p> <p>Rear-mounted RS232 SUB-D9 socket or RS485 interface (terminal connection) for data/program transmission or as modem connection. The following baudrates are supported: 1200, 2400, 4800, 9600, 19200, 38400, 57600, 115200 Max. line length with shielded cable: 2 m (6.6 ft) (RS232), or 1000 m (3281 ft) (RS485) Both interfaces are galvanically isolated from the system. The RS232/RS485 interfaces cannot be used simultaneously.</p>

Performance characteristics

Reference operating conditions	Ambient temperature: 25 °C ± 5 K (77 °F ± 9 °F) Air humidity: 55 % ± 10 % r.h.
Maximum measured error	(See Input)
Temperature drift	Cu100, Cu50, Cu53, Pt46 and Pt50: max. ± 0.02 %/K (of measuring range) All other ranges: max. ± 0.01 %/K (of measuring range)
Long-term drift	To IEC 61298-2: max. ± 0.01 %/month (of measuring range)

Installation conditions

Orientation Position of use as per DIN 16 257, NL 90 ± 30°

Installation instructions Panel cutout and installation / design, dimensions:

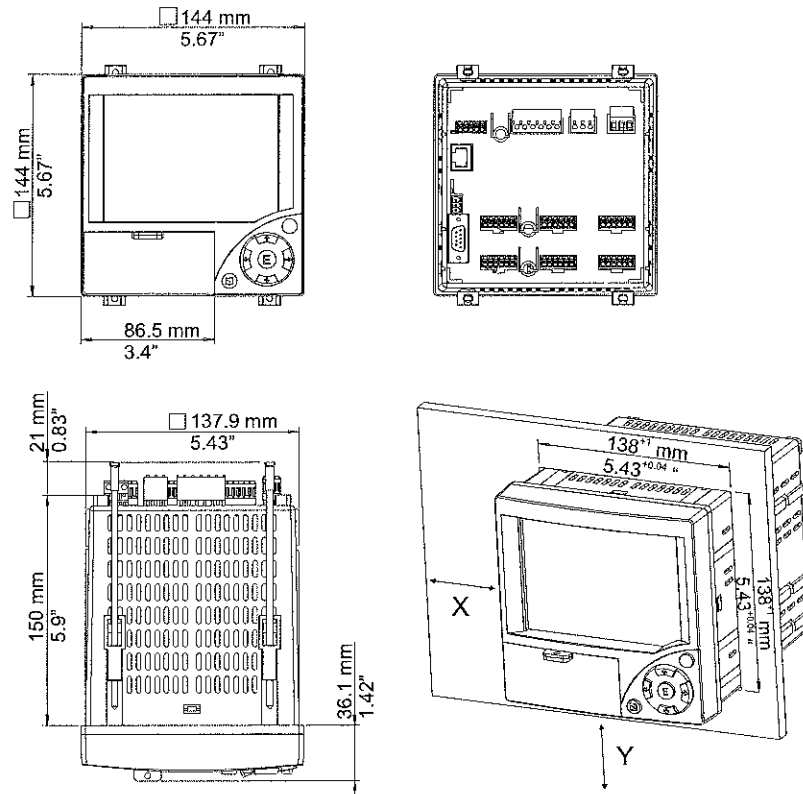

- Installation depth: approx. 171 mm (6.73 inch) (incl. terminals and fastening clips)
- Panel cutout: 138⁺¹ x 138⁺¹ mm (5.43^{+0.04} x 5.43^{+0.04} inch)
- Panel thickness: 2 to 40 mm (0.08 to 1.57 inch)
- Maximum point of view range: From the display center 50° to the left and right, 20° upward, 30° downward.
- Securing to DIN 43 834



Note!

A distance of min. 15 mm (0.59 in) between the units has to be observed if aligning the units in the Y-direction (vertically above one another).

The units can be arranged horizontally beside one another in the X direction without any spacing between the units.

Environment

Ambient temperature range	0 to 50 °C (32 to 122 °F)
Storage temperature	-20 to +60 °C (-4 to 140 °F)
Relative air humidity	0 to 50 °C (32 to 122 °F), max. 75% humidity without condensation.
Climate class	To IEC 60654-1: B1

Degree of protection	Front-panel IP 54 (IEC 60529, Cat. 2) NEMA 2 rear-panel IP 20 (IEC 60529, Cat. 2)
-----------------------------	--

Electrical safety	IEC 61010-1, protection class I Low voltage: overvoltage category II Environment < 3000 m (< 9843 ft) above MSL (mean sea level)
--------------------------	--

Electromagnetic compatibility (EMC)	<p>Interference immunity:</p> <p>To IEC 61326: Class B (industrial environment) and NAMUR NE21:</p> <ul style="list-style-type: none"> ■ ESD (electrostatic discharge): IEC 61000-4-2 severity 3 (6/8 kV) ■ HF field (electromagnetic interference fields): IEC 61000-4-3: severity 3 (10 V/m) ■ Burst (quick transient disturbance variables): IEC 61000-4-4 severity 3 (1 kV signal, 2 kV power supply) ■ Surge on power line: IEC 61000-4-5: 2 kV asymmetrical, 1 kV symmetrical ■ Surge on signal line: IEC 61000-4-5: 1 kV asymmetrical (with external protection element) ■ Conducted HF: IEC 61000-4-6: 150 kHz to 80 MHz, 10 V ■ Power failure: IEC 61000-4-11 (> 20 ms/0%) ■ Voltage variation: IEC 61000-4-11 (40% / 0%) <p>Emission:</p> <p>To IEC 61326: Class A (operation in industrial environment)</p> <p>Interference voltage:</p> <p>Power line: To CISPR 16-1/-2: Class A</p> <p>Interference current:</p> <p>Ethernet line: To EN 50022: Class A</p> <p>Interference field intensity:</p> <p>Housing/all connections: to CISPR 16: Class A</p> <p>Interference voltage suppression:</p> <ul style="list-style-type: none"> ■ Common mode interference voltage suppression: IEC 61298-3: Analog inputs: 80 dB at 60 V and 50 Hz / 60 Hz ■ Push-pull interference voltage suppression: IEC 61298-3: Analog inputs: 40 dB at 50 Hz / 60 Hz, for measuring range/10
--	--

Mechanical construction

Design, dimensions	See Installation conditions
---------------------------	-----------------------------

Weight	Panel-mounted instrument: approx. 700 g (1.54 lb)
---------------	---

Materials	Front frame / removable media door: plastic (ABS) Housing: fibre-glass reinforced plastic (PC) Protective cover in front of display: plastic (PC)
------------------	---

Human interface

Display elements	<p>Type:</p> <p>LC color graphic display</p> <p>Size (screen size, measured diagonally):</p> <p>120 mm (4.7")</p>
-------------------------	---

Resolution:

76,800 pixels (320 x 240 pixels)

Rear illumination:

50,000 h half value time (= half brightness)

Number of colors:

64 colors

Point of view:

Maximum point of view range: From the display center 50° to the left and right, 20° upward, 30° downward.

Display modes:

Curves/load curves, curves in ranges, digital display, bar graph, events list (set points/power failure), status display, history display in curve form with display of digital measured values, date and time

Operating elements**Keyboard:**

Option of operation and configuration via 7 push buttons on the front side in interactive dialog with the screen or using the provided PC software. Display of integrated operating instructions at the push of a button.

Data storage**Save cycle:**

- Selectable save cycle: 1s / 2s / 3s / 4s / 5s / 10s / 15s / 20s / 30s / 1min / 2min / 3min / 4min / 5min / 10min / 30min / 1h

Selected save cycle	Equal to a feed rate in mm/h	Equal to a feed rate in inch/h
1s	1000	40
2s	600	24
3s	300	12
4s	240	10
10s	120	4.8
20s	60	2.4
30s	30	1.2
1min (60s)	20	0.8
2min (120s)	10	0.4
4min (240s)	5	0.2

Internal memory:

- Program memory: 2 MB Flash (nonvolatile)
- Setup data memory, measured data memory: permanent back-up of setup data and measured data in internal Flash memory (nonvolatile)
- Main memory: 2 MB SRAM
Data buffering and RTC buffering with lithium cell (replace after 10 years)

External memory:

- Cyclic copying of the measured data for archiving on CompactFlash card (CompactFlash base: type I)
- Supported CF memory cards : 32 MB, 64 MB, 128 MB, 256 MB and 512 MB. Please use the CF memory cards recommended by the manufacturer (see "Accessories").

- A green LED beside the CF slot indicates data access. During this process, the CF card must not be removed. Risk of losing data!

Typical recording lengths:

Requirements for the following tables:

- No alarm point violation/event storage
- Digital input not used
- Signal analysis deactivated



Note!

Frequent entries in the events list reduce the memory availability!

Internal memory (weeks = w, days = d, hours = h):

Analog inputs	Save cycle 5 min.	Save cycle 1 min.	Save cycle 30 s.	Save cycle 10 s.	Save cycle 1 s.
1	68 w, 5 d, 0 h	15 w, 1 d, 23 h	7 w, 4 d, 11 h	2 w, 3 d, 19 h	1 d, 18 h
3	34 w, 2 d, 12 h	7 w, 1 d, 20 h	3 w, 4 d, 10 h	1 w, 1 d, 11 h	20 h
6	19 w, 4 d, 10 h	4 w, 0 d, 11 h	2 w, 0 d, 5 h	4 d, 17 h	11 h

CompactFlash 128 MB (weeks = w, days = d, hours = h):

Analog inputs	Save cycle 5 min.	Save cycle 1 min.	Save cycle 30 s.	Save cycle 10 s.	Save cycle 1 s.
1	5738 w, 6 d, 14 h	1276 w, 4 d, 7 h	638 w, 2 d, 3 h	212 w, 5 d, 9 h	21 w, 1 d, 22 h
3	2869 w, 4 d, 2 h	606 w, 4 d, 10 h	303 w, 2 d, 5 h	101 w, 0 d, 17 h	10 w, 0 d, 18 h
6	1639 w, 6 d, 0 h	339 w, 4 d, 18 h	169 w, 5 d, 21 h	56 w, 4 d, 7 h	5 w, 4 d, 15 h

CompactFlash 256 MB (weeks = w, days = d, hours = h):

Analog inputs	Save cycle 5 min.	Save cycle 1 min.	Save cycle 30 s.	Save cycle 10 s.	Save cycle 1 s.
1	11526 w 3 d, 0 h	2564 w, 0 d, 5 h	1282 w, 0 d, 2 h	427 w, 2 d, 8 h	42 w, 5 d, 3 h
3	5763 w, 3 d, 2 h	1218 w, 2 d, 20 h	609 w, 1 d, 10 h	203 w, 0 d, 11 h	20 w, 2 d, 3 h
6	3293 w, 4 d, 3 h	682 w, 1 d, 16 h	341 w, 0 d, 20 h	113 w, 4 d, 22 h	11 w, 2 d, 14 h

Calculation of recording duration:

Calculation of recording duration using "storage calculator" (can be found under "tools" on the CD-ROM of the PC software supplied).

Real time clock (RTC)

Switchable summer time/normal time automated system
 Power reserve: buffering via lithium battery
 Deviation: < 10 min./year
 Time synchronization possible

Remote operation

Configuring and archiving the unit settings with CompactFlash or with supplied PC software via rear-mounted serial interface RS232/RS485 (e.g. modem), Ethernet, or front-mounted USB port.

Certificates and approvals

CE mark	The measuring system meets the legal requirements of the EC directives. The manufacturer confirms successful testing of the device by affixing the CE mark.
UL listed for Canada and USA	The device was examined by Underwriters Laboratories Inc. (UL) in accordance with the standards UL 61010-1 and CSA C22.2 No. 61010-1 and listed under the number E225237 UL.
Other standards and guidelines	CSA approval CAN/CSA-C22.2 No. 61010-1-04 Safety requirements for electrical equipment for measurement, control, and laboratory use - General requirements, Second Edition.

Ordering information

Product structure	Basic features: 4.7" LC colour graphic display (320 x 240 pixels) Analog inputs, 3 digital inputs, 4 relays Interactive dialogue operation with 7 push buttons 24 V auxiliary output voltage USB connection incl. connecting cable 16 limit values, can be freely defined PC software package CompactFlash (CF) slot				
	Input signal				
	A	3 universal (U, I, TC, RTD)			
	B	6 universal (U, I, TC, RTD)			
	Power supply				
	1	100-230 V AC ($\pm 10\%$), 50/60 Hz			
	2	24 V AC/DC, 50/60 Hz			
	Interface				
	A	USB			
	B	USB + RS232/485 + Ethernet			
	Memory medium				
	1	without CF card			
	3	CF card industrial grade, 256 MB			
	4	CF card industrial grade, 128 MB			
	Housing				
	A	Panel 144x144 mm (5.67 x 5.67"), IP54, NEMA 2			
	C	Desk top, cable plug earth. type			
	D	Desk top, cable plug US			
	E	Desk top, cable plug Suisse			
	F	Field housing, IP65, NEMA 4x			
	Operation language				
	A	Standard (German, English)			
	B	Central/western Europe (German, English, French, Spanish, Italian, Dutch)			
	C	Northern Europe (German, English, Danish, Swedish)			
	D	Eastern Europe (German, English, Polish, Russian, Czech, Slovak)			
	E	America (German, English, French, Spanish, American, Portuguese)			
	F	Japan (German, English, Japanese)			
	G	China (German, English, Chinese)			
	Additional option				
	A	Standard			
	C	Integration + Analysis + Maths			
	Approval				
	1	Non-hazardous area, standard with logo			
	2	Non-hazardous area, neutral without label			
RSG30-					← Order code

Accessories

Scope of delivery

- Unit (with terminals, as per your order)
- 4 fastening clips
- USB cable
- Optional CompactFlash CF card (CF card is enclosed separately.)
- PC operating and configuration software on CD-ROM
- Delivery note
- Multilanguage Brief Operating Instructions as hard copy
- Operating Instructions on CD-ROM
- locking plate

Anything missing? Then please inform your supplier.

Accessory parts

The following accessories are available:

Order code	Accessory
50078843	Terminal, pluggable, 3-pole, for power supply
51009211	Terminal, pluggable, 6-pole, for analog input
51009214	Terminal, pluggable, 3-pole, for relay
51009215	Terminal, pluggable, 6-pole, for relay
71062537	Terminal, pluggable, 5-pole, for digital I/O
71043991	CompactFlash (CF) memory card 128 MB
51009640	CompactFlash (CF) memory card 256 MB
71007465	Cable USB-A - USB-B, 2 m (6.56 ft)
RXU10-A1	Cable set for connection PC or modem
RSG30A-S3	Adapter set RS232/RS485 230 VAC in compact housing, without galvanic isolation
RSG30A-S5	Adapter set RS232/RS485 115 VAC in compact housing, without galvanic isolation
RSG30A-S6	Adapter set RS232/RS485 for DIN rail 230 VAC with galvanic isolation and interface cable for PC/modem
RSG30A-S7	Adapter set RS232/RS485 for DIN rail 115 VAC with galvanic isolation and interface cable for PC/modem
RSG30A-H1	Field housing IP65

Documentation

- Brochure on recording technology (FA014R/09/en)
- Operating Instructions (BA194R/09/en)
- Brief Operating Instructions (KA199R/09/c5)

Instruments International

Endress+Hauser
Instruments International AG
Kaegenstrasse 2
4153 Reinach
Switzerland

Tel. +41 61 715 81 00
Fax +41 61 715 25 00
www.endress.com
info@ii.endress.com

Endress+Hauser 
People for Process Automation

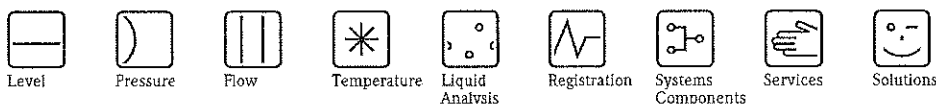

Technical Information

ASP Station 2000

Stationary Water Sampler
Automatic sampler for liquid media

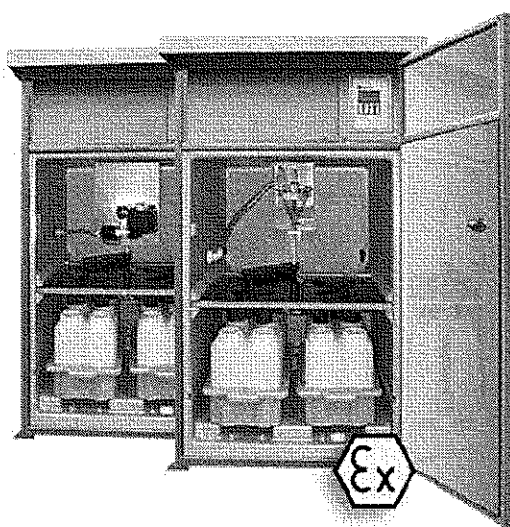

Application

Municipal and industrial sewage treatment plants:

- Self monitoring
- Efficiency monitoring; cleaning performance determined
- Curve recording
- Process monitoring
- Monitoring of indirect dischargers
- Monitoring of wastewater network

Laboratories and Water Conservancy Boards:

- Hydrology and drinking water supply (e.g. dam monitoring)
- Monitoring of direct and indirect dischargers

Monitoring of liquid media in industrial processes.

Your benefits

Robust and dependable

- Stainless steel cabinet with foamed insulation, for safe sample preservation
- Sample compartment with seamless inner shell and evaporator in foam – no freezing and no corrosion of cooling plates

Simple and user-friendly

- Menu-led operation with “Quick-Setup”, for quick commissioning
- Media-carrying parts easy to mount without tools, for easy cleaning and maintenance
- Separate bottle trays with grips, for easy sample transportation

Flexible

- Parallel sampling, switching and event programmes for practical programming
- Modular installation of electrical components for extended functions

Communicative

- Integrated data logger, for recording measured values (e.g. pH value) and sample statistics (standard in the case of ASP station 2000 peristaltic, optional in the case of ASP station 2000 vacuum)
- RS232 interface for configuration, data transmission and read-outs from internal data logger (optional in the case of ASP station 2000 vacuum)
- Profibus-DP interface, for connection and control with control systems (optional in the case of ASP station 2000 vacuum)
- Connection possibility for multiparameter sensor (optional in the case of ASP station 2000 peristaltic)

Safe

- ATEX II 3G certification for safe operation in zone 2 hazardous areas (optional in the case of ASP station 2000 vacuum)
- Trouble-free sampling operation in case of power failure by means of battery buffering in the case of ASP station 2000 peristaltic

Function and system design

Measuring principle

The ASP station 2000 is a stationary sampler for fully automated sampling, defined distribution and thermostatic storage of liquid media.

Sampling methods

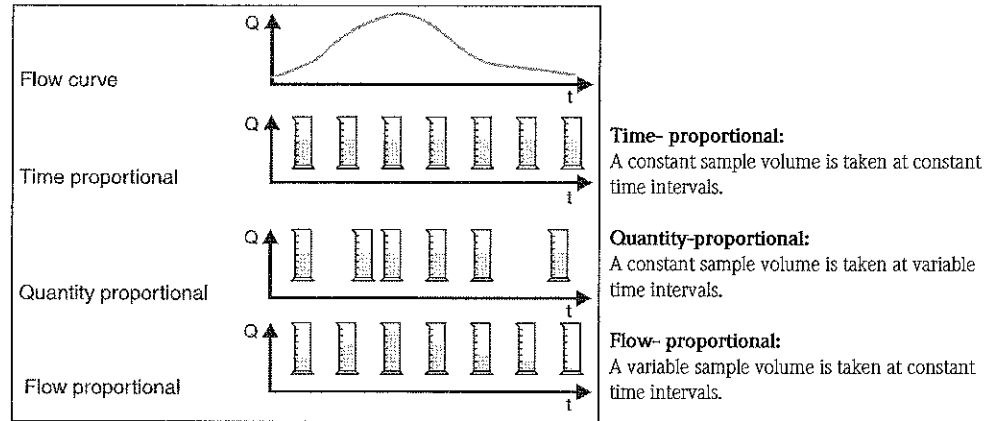

Sampling unit

ASP station 2000 with vacuum system

There are four stages in the sampling process:

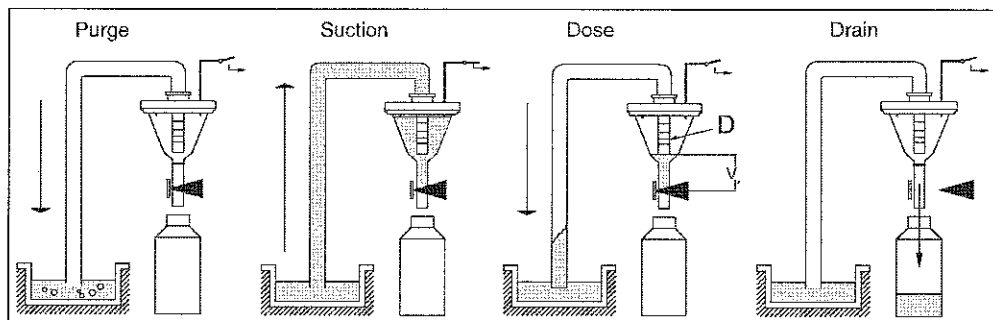

1. **Blow out:**
The diaphragm pump blows the suction line clear via the dosing system.
2. **Suction:**
The "Airmanager", a pneumatic ratchet gear, switches the air pipe of the diaphragm pump to suction mode. The sample liquid is drawn into the dosing funnel until the conductivity probes of the dosing system are reached.
3. **Dose:**
The suction process is stopped. Depending on the position of the dosing pipe (item D), the excess sample liquid flows back to the sampling point.
4. **Drain:**
The hose constriction is opened and the sample is drained into the sample bottle.

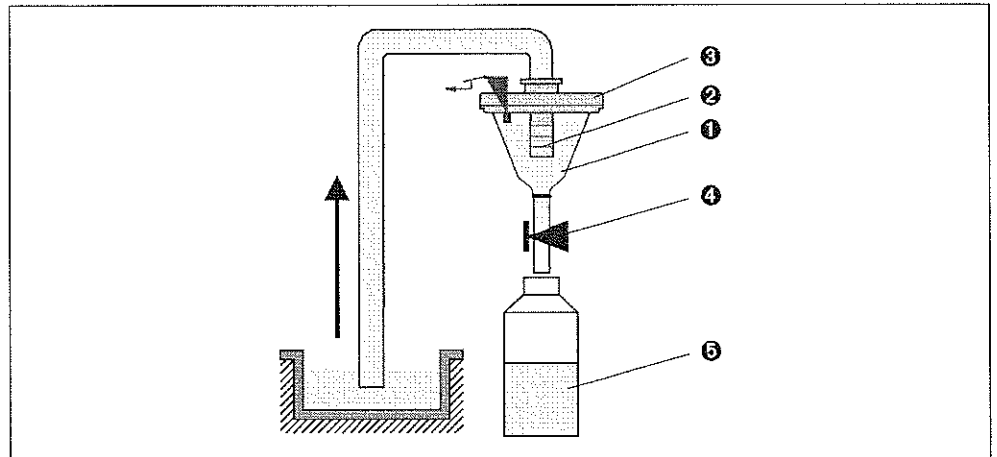

Sampling principle

- Item 1 : dosing funnel*
- Item 2 : dosing pipe*
- Item 3 : dosing funnel lid*
- Item 4 : hose constriction*
- Item 5 : sample bottle*

The sampling liquid is extracted discontinuously by means of a vacuum system. The vacuum system of the ASP station 2000 consists of the following components:

- Vacuum diaphragm pump
- Wear-resistant, pneumatic "Airmanager" step ratchet gear"
- Dosing system (see table below)

Dosing systems, ASP station 2000 vacuum system

Standard	Twiddle principle
<p><i>Standard dosing system</i></p> <ul style="list-style-type: none"> <i>Item A: conductivity probe (long)</i> <i>Item B: conductivity probe (long)</i> <i>Item C: conductivity probe (short)</i> <i>Item D: dosing pipe</i> 	<p><i>"Twiddle principle" dosing system</i></p> <ul style="list-style-type: none"> <i>A: inlet</i> <i>B: rotatable pipe</i> <i>C: stationary pipe</i> <i>D: outflow sample container</i>

Standard	Twiddle principle
<ul style="list-style-type: none"> ■ There are three conductivity probes in the dosing funnel lid. During the suction process, the sample liquid first reaches the longer conductivity probes (item A and B). In this way, the filling of the dosing funnel is detected and the suction process is stopped. If the conductivity probes (item A and B) fail, safety switch-off takes place by means of the shorter conductivity probe (item C). ■ The sample volume is set between 20 ml and 200 ml by moving the dosing pipe (item D). ■ The dosing system can be disassembled and cleaned easily without tools. 	<ul style="list-style-type: none"> ■ Inside the dosing system there is a stationary, vertical pipe with an oblong hole and a rotatable pipe with a spiral-shaped cut-out (see diagram Seite 3). By rotating the pipe with the spiral-shaped cut-out, the vertical position of the opening is changed. This in turn changes the dosing volume. ■ The sample volume is changed using a motor and is configured via the controls. The sample volume cannot be changed manually. ■ When sampling starts, the upcoming current flow is queried, and the relevant dosing volume is configured as early as during the blow-out phase. ■ In addition to flow-proportional sampling, time- and quantity-proportional programmes with different dosing volumes are also possible.

ASP station 2000 peristaltic system

A hose pump is used to suck in and dose the sampling liquid. The pump hose is periodically twisted by rollers running along the circumference of the hose, thereby generating a pump effect. The medium detection system controls the electronic volume measurement.

The medium detection system is a new system developed by Endress+Hauser. A pressure sensor is at the heart of the system. The pressure sensor detects the difference between a full and empty pump line.

The advantages of the Endress+Hauser system:

- Intelligent: the suction height is detected automatically and does not need to be configured
- Maintenance-free: ceramic diaphragm

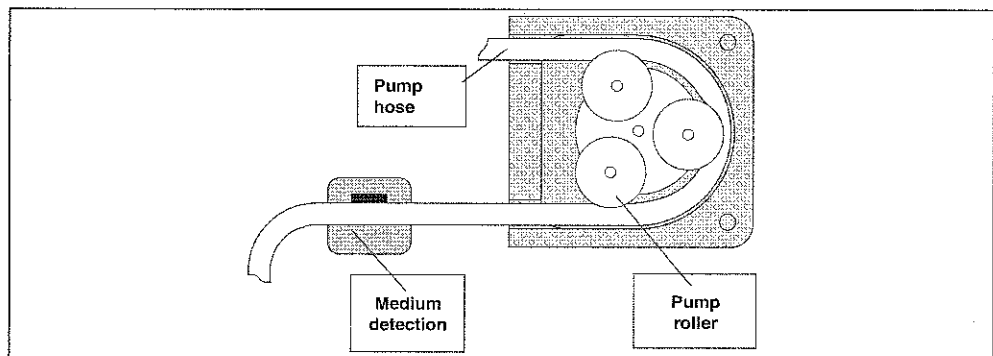

How the hose pump works

Sampling takes place in three steps:

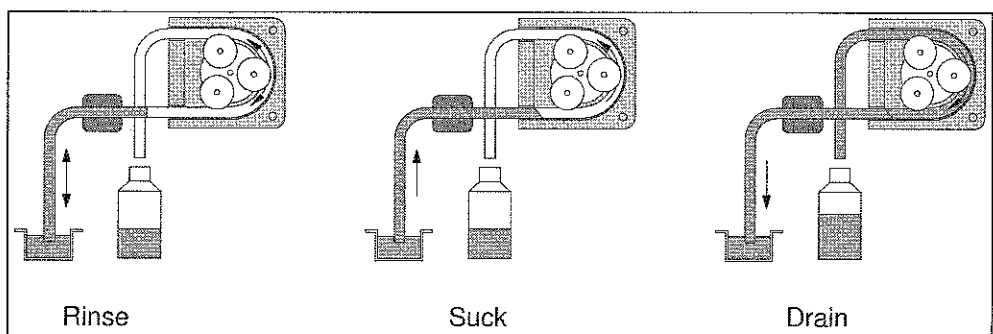

Sampling steps

- Rinsing the suction line: the sampling liquid is sucked in until the medium detection system is triggered. Then the pump reverses and pushes the liquid back to the sampling point. The rinsing process can be repeated up to three times.
- Sucking the sampling liquid: the sampling liquid is drawn from the sampling point to the sampler, and the sample volume is calculated electronically.
- Emptying the suction line: after sampling, the liquid remaining in the suction line is pumped back to the sampling point.

Dosing system data

System	Vacuum		Peristaltic
	Standard	Twiddle principle	
Sampling methods	<ul style="list-style-type: none"> ■ quantity-proportional ■ time-proportional 	<ul style="list-style-type: none"> ■ flow-proportional ■ quantity-proportional ■ time-proportional 	<ul style="list-style-type: none"> ■ flow-proportional ■ quantity-proportional ■ time-proportional
Dosing volume	20 to 200 ml (20 to 500 ml optional)		20 to 9999 ml
Dosing accuracy	4% of the set volume		± 5 ml or ± 5 % of the set volume
Repeating accuracy	2%		5%
Conveying velocity	> 0.5 m/s, to EN 25667		
Conveying height	max. 6 m (8 m optional)		
Conveying distance	max. 30 m		

Sample distribution (vacuum and peristaltic)

The sample liquid is distributed into the individual bottles by means of a tap (item A). In addition to a 30 l and 60 l composite container, various bottle distributions are available. The distribution version can be replaced or changed easily without the need for tools. The ASP station 2000 allows flexible configuration of the sample distribution. Individual bottles and bottle groups can be freely defined for the main, switching and event programmes. Individual bottles are located in two separate bottle trays (item C). Grips on the bottle trays make transportation easy and practical.

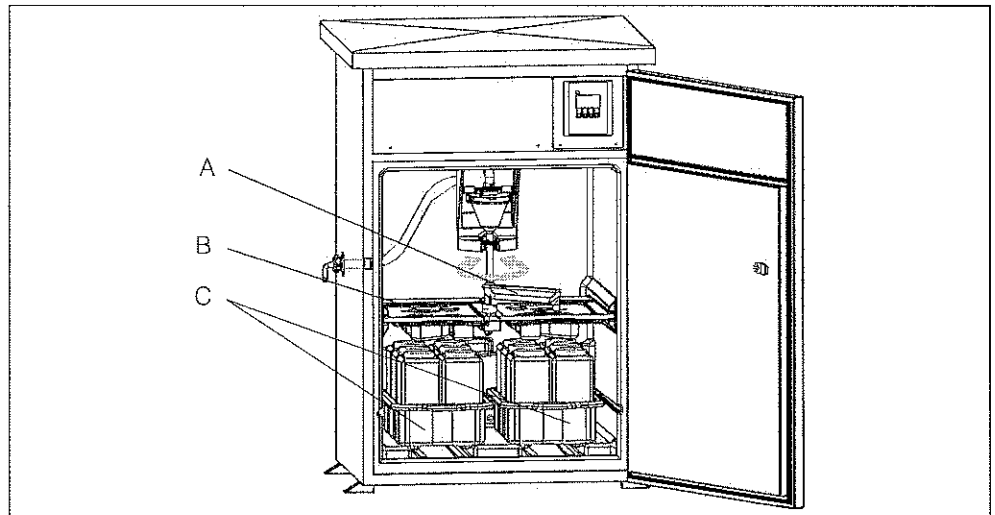

ASP station 2000 sample distribution

- Item A: tap*
- Item B: distribution pan*
- Item C: bottle trays*

Sample preservation

The sample bottles are located in the wet room of the sampler. The sample compartment temperature can be set directly at the controls from +2 to +20 C (factory setting: +4 C). The current sample compartment temperature is displayed at the controls and recorded in the internal datalogger (optional). The evaporator and defrost heater are packed in the PU insulation behind the inner shell, protected against corrosion and damage. The compressor and liquefier are located in the upper section of the sampler. All parts carrying media (e.g. tap, dosing system, distribution pans) can be easily disassembled and cleaned without tools. The entire sample compartment is fitted with a seamless plastic inner shell for easy and effective cleaning.

Power supply

**Electrical connection
(wiring diagram)**

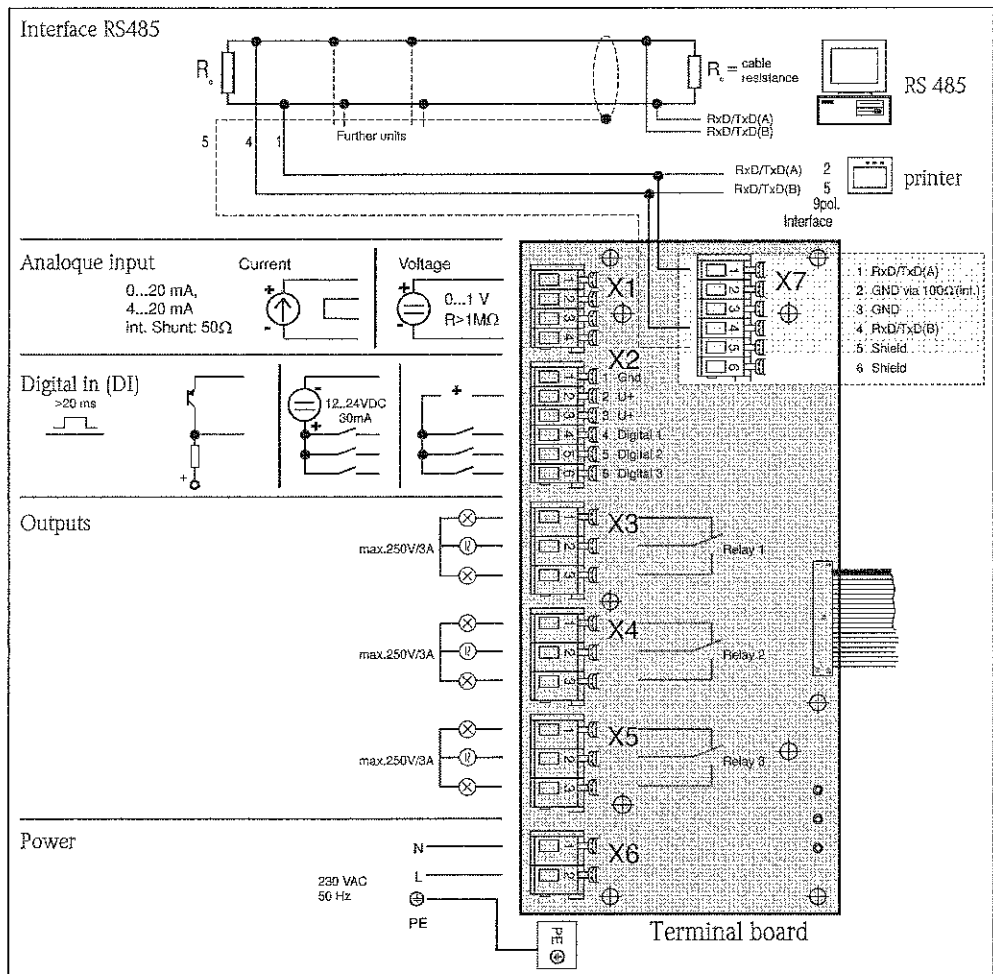

Terminal assignment of the ASP Station 2000

Terminal assignment, ASP station 2000 peristaltic

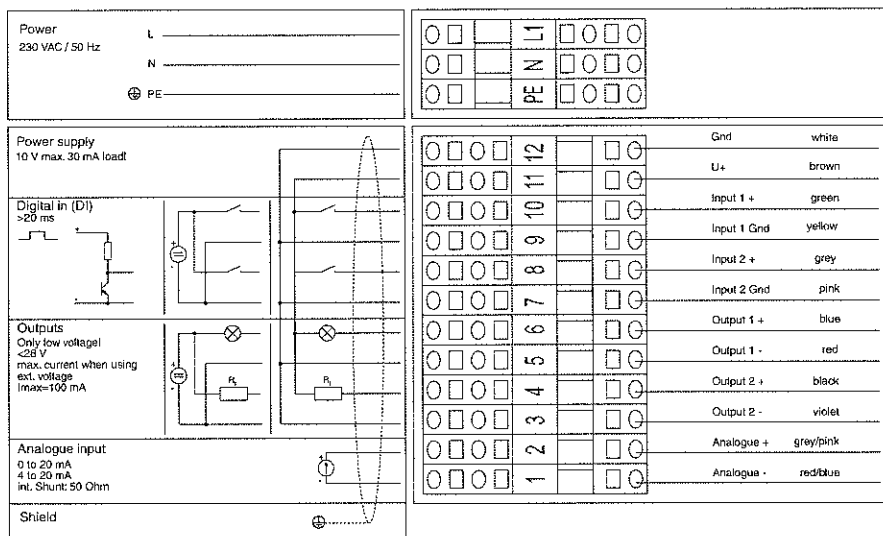

Assignment and circuit diagram of terminal block, ASP station 2000 peristaltic

Supply voltage 230 V AC, 50 Hz
 110-125 V, 50/60 Hz
 Fuse protection at installation max. 10 A
 Peristaltic: battery operation for sampling with charger and storage battery 12 V/12 Ah; trouble-free operation even in case of short-term power failure

Cable entry

- 2 x cable gland M16
- 2 x cable gland M20
- 2 x cable gland M32

Cable specification Power supply: e.g. NYY-J, 3-core, 1.5 mm² - 2.5 mm²
 Analogue and signal lines: e.g. LiYY 10 x 0.34 mm²
 Interface RS485: e.g. LiYCY 2 x 0.25 mm²

Power consumption Vacuum 350 W; peristaltic approx. 340 W

Connection data interface **Serial interface**

- RS485 on terminal board (not peristaltic)
- RS232, 4-pole IP 67 socket IP 67 on the front panel (optional in the case of ASP station 2000 vacuum)

PROFIBUS®-DP connection (optional in the case of ASP station 2000 vacuum)

With Profibus coupler on top-hat rail in electronics compartment via RS232, baudrate 9600 kBaud.

Set-up conditions

Set-up instructions

Suction line

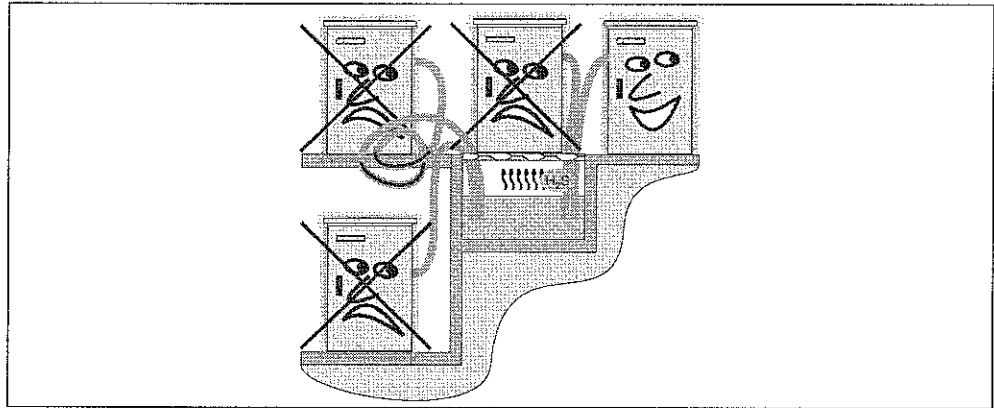

Laying suction line



Note!

The suction line must be laid with a drop to the sampling area (as shown in the illustration). Avoid siphon draw!

Foundations, supports

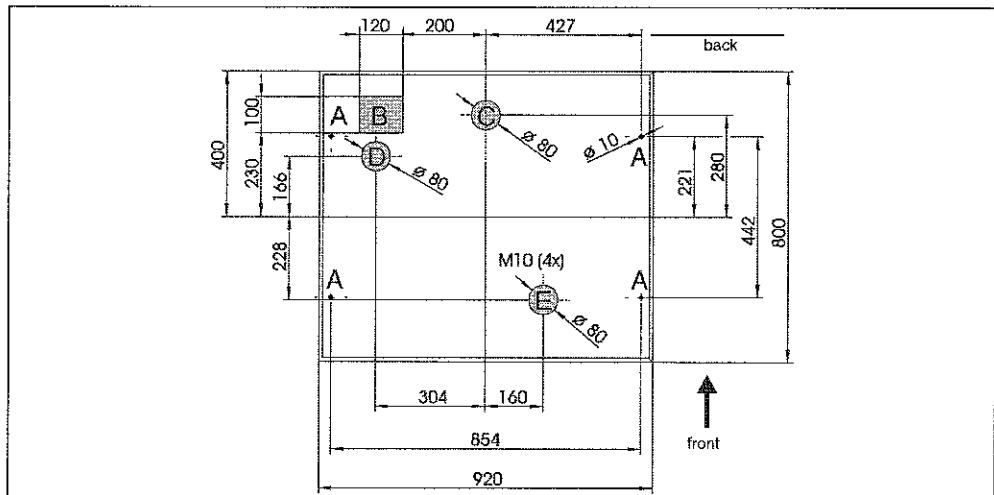

Foundation plan (data in mm)

- A: Fixing points (4 x M10)
- B: Cable pit
- C: Outflow for condensation water
- D: Bottom hose entry (optional)
- E: Outflow for overflow

Environment

Ambient temperature range	-20 to +40 C +5 to +40 C, ASP station 2000 Ex
Storage temperature	-20 to +60 C (preferably at +20 C)
Degree of protection	<ul style="list-style-type: none"> ■ Control (front panel): IP 65 ■ Sample compartment: IP 54 ■ Electronics compartment: IP 43
Electromagnetic compatibility (EMC)	To EN 61 326
Electrical safety	To EN 61010-1, class I protection, environment < 2000 m above sea level

Process

Medium temperature range	0 to +50 °C
Operating pressure range	Unpressurised (standard)
Sample media	<p>ASP station 2000 with vacuum system</p> <p>Pay particular attention to the material resistances of the parts carrying media!</p> <p>Use of capacitive medium detection (optional) with</p> <ul style="list-style-type: none"> ■ Sample media which are high foaming and have high oil/grease content ■ Sample media with a conductivity <30 µS/cm. <p> Caution! Do not sample abrasive media and media containing fibres in flow-proportional dosing systems. Pay attention to the material compatibilities of werred parts.</p>
ASP station 2000 peristaltic system	<p>The sampling media must be free of abrasive substances. Pay particular attention to the material resistances of the parts carrying media!</p>

Mechanical construction

Design, dimensions

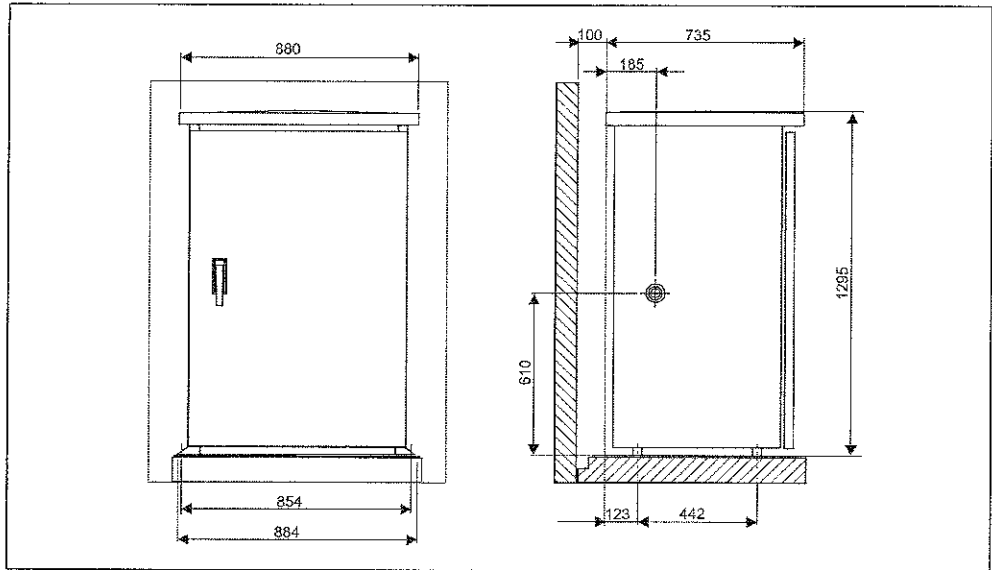

Standard cabinet (dimensions in mm)

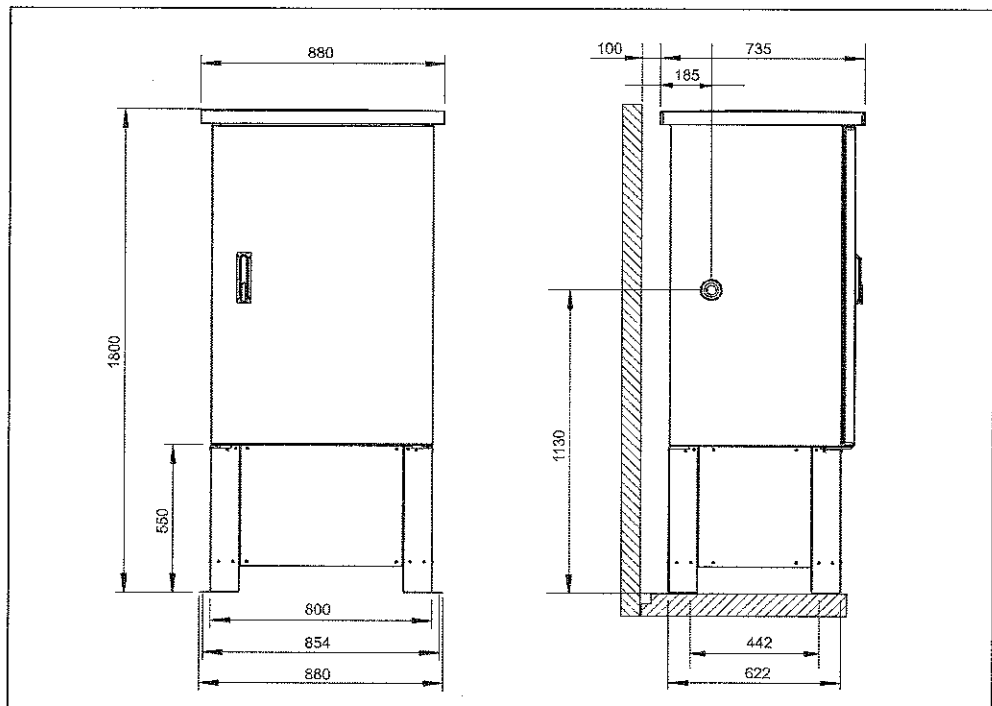

Standard cabinet with cabinet base (dimensions in mm)

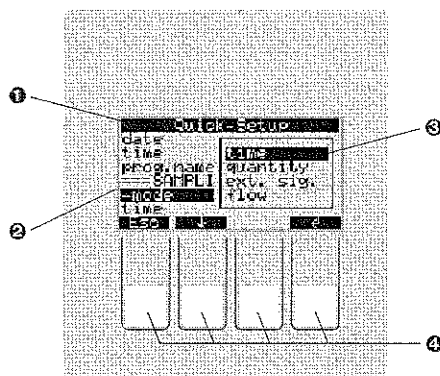

ASP Station 2000 user interface

Item 1: Quick setup

Item 2: Display

Item 3: Menu

Item 4: Operating keys

Remote operation + data logging

The functions described in this section are optional in the case of ASP station 2000 vacuum and standard in the case of ASP station 2000 peristaltic.

Interface

PC interface RS232. It is especially easy to configure the ASP station 2000 (as well as other E+H instruments) with the PC software ReadWin® 2000.

Advantages of the PC software ReadWin® 2000:

- Uniform user interface at the PC under Windows
- Device settings saved in a database
- Device settings read out
- Internal memory read out with measured flow rate, sample quantity taken, etc.

Internal memory

Integrated memory for recording an analogue value (flow, pH value, conductivity, etc.), events (e.g. power failure), sample statistics (e.g. sample volume, filling times, bottle assignment).

Calculation of recording duration

Automatic display when sampling rate is entered.

Certificates and approvals

CE-Mark

The measuring system is in conformity with the statutory requirements of the EC Directives. Endress+Hauser confirms successful testing of the device by affixing the CE mark.

Ex approval

Information about currently available Ex versions (ATEX, FM, CSA) can be supplied by your E+H Sales Centre on request. All explosion protection data are given in a separate documentation which is available upon request.

Other standards and guidelines

- EN 60529:
Degrees of protection by housing (IP code)
- EN 61010:
Protection measures for electrical equipment for measurement, control, regulation and laboratory procedures.
- EN 61326 (IEC 1326):
Electromagnetic compatibility (EMC requirements)

UWWTR

WRc/E32 (Ref: UC 3489), for RPS20

Ordering information

**Ordering information ASP
Station 2000 Vacuum:**

Control unit	
A	1x user mode
B	1x user mode + RS485
C	7x user mode + Profibus preparation
D	7x user mode + RS485 + Profibus preparation
E	7x user mode + RS485 + DFP + Profibus preparation
F	7x user mode + memory + Profibus preparation
G	7x user mode + memory + RS232 cable + ReadWin2000 + Profibus preparation
H	7x user mode + memory + DFP + RS485 + Profibus preparation
I	7x user mode + memory + DFP + RS485 + RS232 cable + Readwin2000 + Profibus preparation
K	7x user mode + Profibus-DP
L	7x user mode + Profibus-DP + DFP + RS485
M	7x user mode + preparation RPM20
N	7x user mode + self draining preparation
Operation language	
A	German
B	English
C	French
D	Italian
E	Spanish
F	Dutch
G	Danish
K	Czech
P	Polish
Sample distribution	
A	W/o
B	1x 30 litre composite container, PE
C	1x 60 litre composite container, PE
N	4x 12 litre bottle, PE
L	4x 20 litre bottle, PE
E	D12x 3 litre bottle, PE
F	24x 1 litre bottle, PE
G	12x 2 litre bottle, glass
H	24x 1 litre bottle, glass
O	6x 3 + 2x 12 litre bottle, PE
P	12x 1 + 2x 12 litre bottle, PE
K	12x 1 + 6x 3 litre bottle, PE
Hydraulic connection; suction height	
1	Left; max. 6m
2	Bottom; max. 6m
3	Left; max. 8m
4	Bottom; max. 8m
5	Flow through armature, external feed
6	Right; max. 6m
7	Right; max. 8m
A	Left; sampling RPM20, order separately)
B	Right; sampling RPM20, order separately)
Cabinet	
A	Stainl. steel 304H
B	Stainl. steel 316L
C	Stainl. steel 304H + window
D	Stainl. steel 304H + door stop
E	Stainl. steel 304H, w/o cooling
F	Stainl. steel 316L + refrig. system varnished
G	Stainl. steel 304H + 2x door + window
H	Stainl. steel 316L + 2x door + window + refrig. system varnished
I	Stainl. steel, 304H + refrig. system varnished
RPS20-	← order code (part 1)

Cabinet accessories: Dosing chamber					
					1 W/o; Acryl chamber
					2 Base, stainl.steel 304H; Acryl
					3 Base, stainl.steel, 316L; Acryl
					4 Castors + handle; Acryl
					5 Rodent protection; Acryl
					6 W/o; glass
					7 W/o; glass + capacitance switch
					8 W/o; glass + Liquiphant switch
Electrical variations					
					A W/o
					B Main switch
					C Internal lighting
					D Main switch + internal lighting
					E Overvoltage protection, Main
					F Earth leakage trip, 2-pole, 30mA
					H Measuring pH / temp., CPM223-PR0105
					I Measuring conductivity, CLM223-CD0005
					K Measuring pH / temp. + conductivity CPM223-PR0105, CLM223-CD005
					N Medium detection using capacitance switch-off 60/7
					P Power supply 110-125VAC
					R Transmitter 96x96mm, order separatly, Fitting + wiring)
RPS20-					⇐ order code (complete)

**Ordering information ASP
Station 2000 Ex:**

										Certification	
										A	ATEX II 3G Eex nA/C IIC T4
										Y	Other
										Controller/software	
										A	1 user mode
										B	1 user mode + RS485
										Operating language	
										A	German
										B	English
										C	French
										D	Italian
										E	Spanish
										F	Dutch
										G	Danish
										K	Czech
										P	Polish
										Sample distribution	
										A	W/o
										B	1x 30 litre composite container, PE
										C	1x 60 litre composite container, PE
										D	12x 3 litre bottle, PE
										E	24x 1 litre bottle, PE
										F	12x 2 litre bottle, glass
										G	24x 1 litre bottle, glass
										H	12x 1 litre + 6x 3 litre bottle, PE
										I	4x 20 litre bottle, PE
										K	4x 12 litre bottle, PE
										L	6x 3 litre+ 2x 12 litre bottle, PE
										M	12x 1 litre + 2x 12 litre bottle, PE
										Hydraulic connection; suction height	
										1	Left; max. 8m
										2	Bottom; max. 8m
										3	Right; max .8m
										4	Left; flow through armature, external feed
										Cabinet	
										A	Stainl.steel 316L
										B	Stainl.steel 316L + refrig. system varnished
										Y	Other
										Cabinet accessories	
										1	Basic version
										2	Base, stainl.steel, 316L
										3	Castors + handle
										Electrical variations	
										A	Basic version
										Y	Other
RPS22-											⇐ order code (complete)

Ordering information
ASP station 2000 peristaltic

				Power supply	
				1	230VAC50Hz + cooling + heater
				2	110-125V 50/60Hz + cooling + heater
				9	Special version, to be specified
				Control unit	
				A	1x user mode
				B	7x user mode
				C	7x user mode, interface, connection for multiprobe
				Y	Special version, to be specified
				Operating language	
				A	German
				B	English
				C	French
				D	Italian
				E	Spanish
				F	Dutch
				G	Danish
				K	Czech
				P	Polish
				Y	Special version, to be specified
				Sample distribution	
				A	W/o
				B	1x 30 litre composite container, PE
				C	1x 60 litre composite container, PE
				E	12x 3 litre bottle, PE
				F	24x 1 litre bottle, PE
				G	12x 2 litre bottle, glass
				H	24x 1 litre bottle, glass
				K	12x 1 litre bottle + 6 x 3 litre
				L	4x 20 litre bottle, PE
				N	4x 12 litre bottle, PE
				O	6x 3 litre + 2x 12 litre bottle PE
				P	12x 1 litre + 2x 12 litre bottle PE
				Hose tap	
				1	Left
				2	Bottom
				3	Right
				9	Special version, to be specified
				Suction height	
				1	6m
				2	8m
				9	Special version, to be specified
				Cabinet	
				A	Stainless steel 304H
				B	Stainless steel 316L
				C	Stainless steel 304H + door + window
				D	Stainless steel 304H + door stop
				E	Stainless steel 304H + w/o cooling
				F	Stainless steel 316L + refrig. system varnished
				G	Stainless steel 316L + 2x door + window
				H	Stainless steel 316L + 2x door + varnished refrig. system + window
				Y	Special version, to be specified
				Cabinet accessories	
				1	Basic version
				2	Base stainl.steel 304H
				3	Base stainl.steel 316L
				4	Castors + handle
				5	Rodent protection
				9	Special version, to be specified
RPS24-					⇐ order code (part 1)

										Electrical version	
										A	Basic version
										B	Main switch
										C	Internal lighting
										D	Main switch + internal lighting
										E	Overvoltage protection, Main
										F	Earth leakage trip, 2-pole, 30mA
										Y	Special version, to be specified
RPS24-										← order code (complete)	

Accessories

Various accessories can be supplied for the device and they can be ordered separately from Endress+Hauser. More detailed information on the particular order code can be obtained from your local E+H service organisation.

For ASP station 2000			Order code	Accessory
Vacuum	Ex	Peristaltic		
•	•	•	RPS20A-BA	Bottle 1 l PE incl. lid
•	•	•	RPS20A-BB	Bottle 2 l glass incl. lid
•		•	RPS20A-B3	Composite container 30 l
	•		RPS24A-B3	Composite container 30 l
•		•	RPS20A-B6	Composite container 60 l
	•		RPS24A-B6	Composite container 60 l
•	•	•	RPS20A-FB	Bottle tray 6x 3 l PE with bottles
•	•	•	RPS20A-FC	Bottle tray 12x1 l PE with bottles
•	•	•	RPS20A-FD	Bottle tray 6x 2 l glass with bottles
•	•	•	RPS20A-FE	Bottle tray 12x1 l glass with bottles
•	•	•	RPS20A-FF	Bottle tray 2x12 l PE with bottles
•			RPS20A-PA	Profibus DP slave module for top-hat DIN rail mounting from unit software >=V4.10 and 7 programme version
•	•	•	RPS20A-SD	Retro-fit kit castors and handle
•	•	•	RPS20A-SE	Retro-fit-kit cabinet base 1.4301/ss304H
•			RPS20A-SF	Retrofit kit for capacitive detection from unit software >= V2.03
•			RPS20A-SG	Retrofit kit for flow through armature without base and base cover
•	•	•	RPS20A-VA	Distribution system (tap, tap drive, distribution frame)
•			RPS20A-VK	Interface cable with ReadWin 2000 only for option memory
•	•	•	50041303	Bottle 1.0 l glass white with lid
•	•	•	50035320	Lid for 1.0 l bottle PE
•	•	•	50088586	Bottle 3L PE with lid
•	•	•	51002312	Bottle 12 l ASP2000 PE square with lid
•	•	•	51000416	Bottle 20 l ASP2000 with lid
•	•	•	50089636	Distribution pan 6x (distr. 12 bottles)
•	•	•	50089637	Distribution pan 12x distr.24 bottles
•	•		51001074	Suction hose, 13mm, length 3m ASP NBR-rubber/black, inner diameter 13mm
•	•		51001075	Suction hose, 13mm, length 5m ASP NBR-rubber/black, inner diameter 13mm
•	•		51001076	Suction hose 13mm, length 10m ASP NBR-rubber/black, inner diameter 13mm
•	•		50076633	Suction hose, I.D.=16 mm rubber inner diameter 16mm, price per meter
•	•		UE-SDH	Hose weight L=500mm V2A for 16mm suction hose
•	•		50031904	Suction hose, I.D.=19mm PVC PVC reinforced, inflow hose flow through armatur

For ASP station 2000			Order code	Accessory
Vacuum	Ex	Peristaltic		
•	•		50079739	Hose weight L=400mm, V2A, 19mm for 19mm hose
•	•		50031919	Webbed PVC hose 32x5(internal diameter) Drain hose flow through armatur and CE4
•	•		50090886	Hinged submersion holder cpl.
•	•		50079731	Suction filter cpl.PVC,13/15mm sucl.hose
•	•		50079732	Glass dosing chamber 350ml
•	•	•	51004674	Metal TAG SS 25x100
		•	51004744	Spare pump hose 6m package:2 customised tubes for pump head black and white
		•	51004745	Spare pump hose 8m package:2 customised tubes for pump head black and white
		•	51002425	Suction filter 1", V2A
		•	50053928	Suction hose in PVC internal.dia.10mm
		•	50070341	Suction hose in rubber internal dia.10mm
		•	51003189	Hose connection nipple cpl.
		•	51003199	Battery 12V,12Ah cpl.
		•	51003198	Hose end piece cpl. V2A=500mm for 10mm suction hose

Documentation

- Water samplers and measurement stations - Automatic samplers and measurement stations for liquid media (FA 013C/09/en)
- Operating instructions ASP Station 2000 (BA 080R/09/c4)
- Operating instructions ASP Station 2000 peristaltic (BA 176R/09/c4)
- Ex-Supplementary documentation: ATEX, FM, CSA, etc.
- Appendix to the operating manual - ASP Station 2000 DP-Slave-Module_is Pro Gate (ZBA 146R/09/en)
- Appendix to the operating manual - ASP Station 2000 flow proportional sampling "twiddle principle" (ZBA 096R/09/a2)

International Head Quarter

Endress+Hauser
GmbH+Co. KG
Instruments International
Colmarer Str. 6
79576 Weil am Rhein
Deutschland

Tel. +49 76 21 9 75 02
Fax +49 76 21 9 75 34 5
www.endress.com
info@ii.endress.com

Endress+Hauser 
People for Process Automation

Our ref.: C901/100621/gw

Lam Environmental Services
11/F, Centre Point,
181-185 Gloucester Road,
Wan Chai, Hong Kong

Attn: Ms. Cherry Mak

21st June, 2010

Dear Sir/Madam,

Subject: Job Reference of Endress+Hauser Instruments
Turbidity Measurement

We are pleased to provide the job reference of E+H instruments for your information. Please find them as below:

Type	User	Location	Application	Measuring Range (typical)
CUM253/ CUS31 TSS System	Drainage Service Department	DSD Shatin STW	Wastewater Outlet	≤ 10mg/L
CUM253/ CUS31 TSS System	Drainage Service Department	DSD Taipo STW	Wastewater Outlet	≤ 10mg/L
CUM253/ CUS31 TSS System	Drainage Service Department	DSD Stanley STW	Wastewater Outlet	≤ 10mg/L
CUM253/ CUS31 TSS System	Drainage Service Department	DSD Shek Wu Hui STW	Centrate outlet	≤ 500 mg/L
CUM253/ CUS31 TSS System	Drainage Service Department	Various Sites at Sai Kung and Taipo Areas (Clear Water Bay RBC STW, Pik Uk Correctional Institute STW, Pik Uk Prison STW, Pik Uk RBC STW, Razor Hill Trickling Filter STW, Tung Tze Road STW, total 8 sets)	Wastewater Outlet	≤ 10mg/L

Should you have further enquiries, please feel free to contact us at +852 2528 3120.

Best Regards,

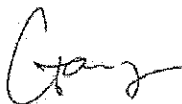

Gary Wong
Endress+Hauser (HK) Limited
gary.wong@hk.endress.com



Submersible Sewage Pumps
Vortex Impeller

PU



Made of stainless steel and special resin, the PU-series submersible pumps are lightweight and rust free. The vortex impeller and large passage facilitate pump operations to readily dispose of liquids containing various kinds of foreign matters.

① Anti-wicking cable entry

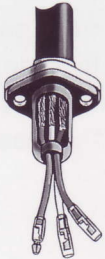

Each cable entry is devised at its entry into the pump so that it may prevent drainage incursion into the motor due to a capillarity.

A portion of each conductor is stripped back and sealed by molded rubber which flows in between each strand of the conductor thus preventing 'wicking.'

the conductor thus preventing 'wicking.'

② Motor

Dry, squirrel-cage induction motor secured in a watertight stainless steel case. Class E insulation is provided. The pump is usable at an ambient temperature of not higher than 40 °C.

③ Motor protector

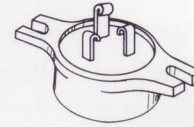

Every PU-series pump is equipped with a motor protection device which directly cuts the motor circuitry in case of an excessive heat buildup in the motor or an overcurrent caused by some electrical or mechanical failure.

④ Back pull-out design

Unfastening the bolts between the oil casing and the upper pump casing allows the body to be separated into the pump section and the motor section with the impeller left in position. This facilitates inspections of the main portions. The pump section can be disassembled/reassembled using a large Phillips screw driver.

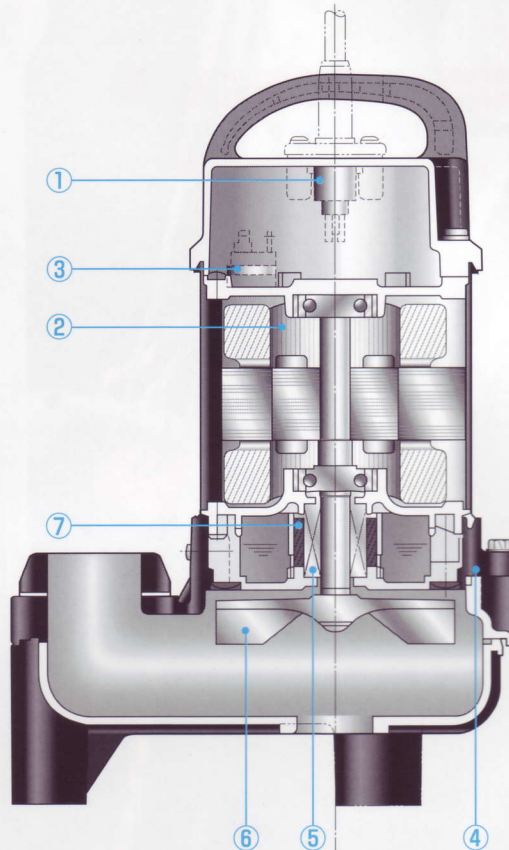

⑤ Mechanical seal

All PU-series pumps are furnished with a dual inside mechanical seal made of silicon carbide. The seal is located in an oil chamber completely outside the drainage so as to eliminate:

- a spring failure, due to corrosion, abrasion or fouling, which can prevent the seal faces from closing properly and/or
- the loss of cooling effects on the bottom seal faces under dry run conditions, which can cause a bottom seal failure.

⑦ Oil Lifter (Pat. Pending)

Every pump has a built-in Oil Lifter designed to stabilize the mechanical seal function by efficiently supplying the lubricant to the seal even if it drops to below the rated level. This amazingly simple device turns otherwise wasted energy into an additional protection effect for the seal and extends both seal life and maintenance intervals.

⑥ Impeller



A vortex impeller is installed in the upper section of the pump casing. The impeller, coupled with a large passage in the casing,

allows the pump to handle coarse solids up to 35 mm in grain diameter.



COMPOSITION OF THE MODEL NAME

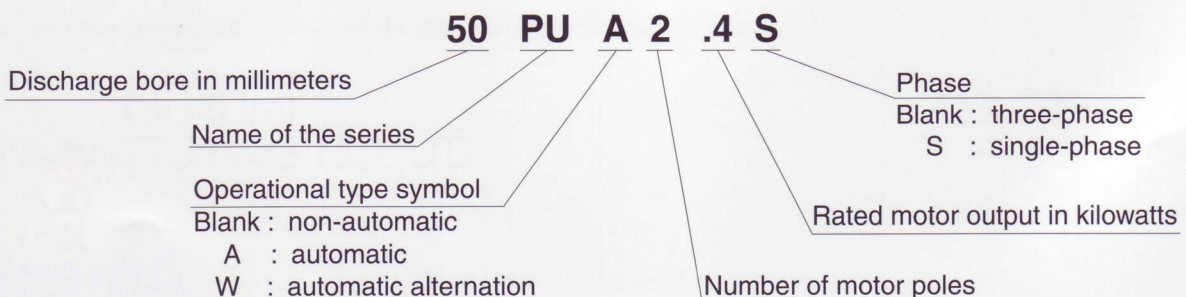

Performance curves

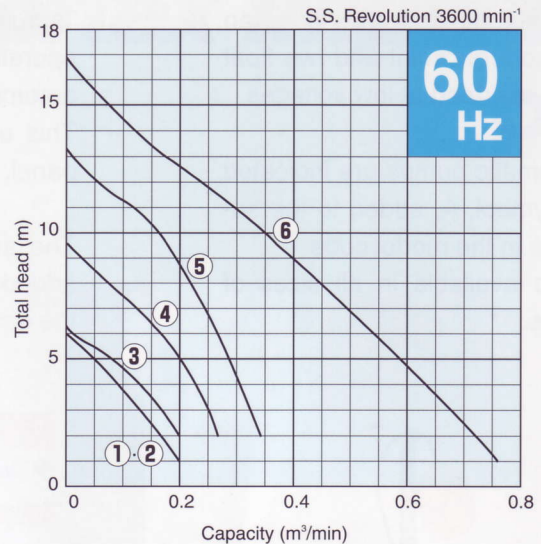
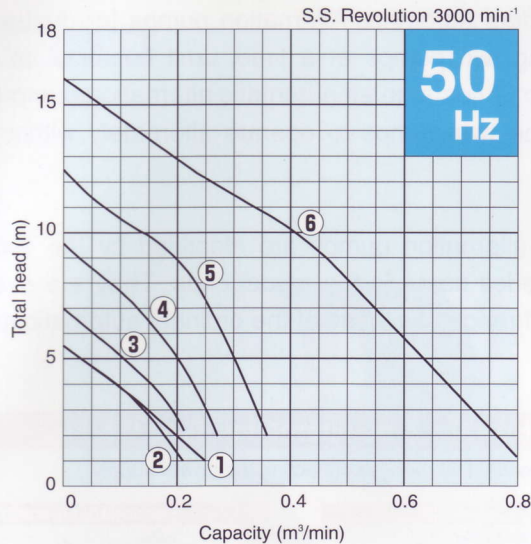

Specifications

Curve No.	Discharge bore mm	Standard Model	Automatic Model	Auto-alternation Model	Motor output kW	Phase	Revolutions 50Hz/60Hz min ⁻¹	Starting method	Impeller passage mm	Standard cable length m	Cable code ref.	Dimensions L H mm		Dry weight kg	
												Standard	Auto & Auto alternation	Standard	Auto & Auto alternation
1	40	40PU2.15S	40PUA2.15S	40PUW2.15S	0.15	Single	3000/3600	Capacitor Run	35	5	a	225×378	225×378	6.6	7.0
2	40	40PU2.15	40PUA2.15	40PUW2.15	0.15	Three	3000/3600	D.O.L.	35	6	A	225×378	225×378	5.8	6.2
3	40	40PU2.25S	40PUA2.25S	40PUW2.25S	0.25	Single	3000/3600	Capacitor Run	35	5	a	236×360	236×374	7.1	7.7
	40	40PU2.25	40PUA2.25	40PUW2.25	0.25	Three	3000/3600	D.O.L.	35	6	A	236×349	236×363	6.1	6.7
4	50	50PU2.4S	50PUA2.4S	50PUW2.4S	0.4	Single	3000/3600	Capacitor Run	35	5	a	236×360	236×374	7.1	7.7
	50	50PU2.4	50PUA2.4	50PUW2.4	0.4	Three	3000/3600	D.O.L.	35	6	A	236×360	236×374	7.0	7.5
5	50	50PU2.75S	50PUA2.75S		0.75	Single	3000/3600	Capacitor Run	35	5	a	236×374	236×388	8.9	9.5
	50	50PU2.75	50PUA2.75	50PUW2.75	0.75	Three	3000/3600	D.O.L.	35	6	A	236×374	236×388	8.3	8.9
6	80	80PU21.5	80PUA21.5	80PUW21.5	1.5	Three	3000/3600	D.O.L.	46	6	A	295×475	295×475	15.8	16.5

Cable

Single-Phase

Code	Pcs/unit	Cores × mm ²	Dia. mm	Material
a	1	3 × 1.25	10.1	PVC Sheath

Three-Phase

Code	Pcs/unit	Cores × mm ²	Dia. mm	Material
A	1	4 × 1.25	11.1	PVC Sheath

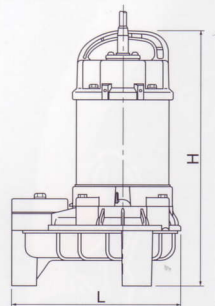

Special Accessory

TOK guide rail fittings

Tsurumi provides TOK-type guide rail fittings for all PU-series pumps. The fittings connect a pump to, or separate it from, piping only by lifting the pump up/down. No need to enter in the pump sump for maintenance.

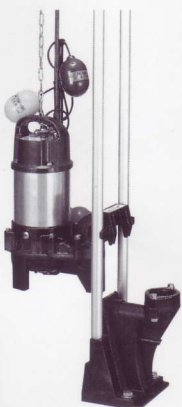

Advantages

No water leak

Rubber bellows attached to the guide hook are inverted to the duckfoot bend when the pump starts operation. The bellows are kept inverted while the pump is stopped. This eliminates leaks even if a lightweight pump is connected with the guide hook.

Immune to rust

The guide hook, guide support and duckfoot bend are made of high-quality resin and secured in position with stainless steel bolts and washers. This prevents corrosion completely.

Type of TOK and applicable pumps:

TOK Model	Applicable Pump Models
TOK4-P	Pumps of 0.15kW to 0.75kW
TOK2-65	Model 80PU21.5

Contents of TOK

- 1 × Duckfoot Bend
 - 1 × Upper Guide Support
 - 1 × Guide Hook
 - 1 × Lifting Chain(4m by TOK4-P, 5m by TOK2-65)
 - 1 × Rubber Bellows
- (The foundation bolts, two numbers required, are not included.)

Automatic pumps

Tsurumi Automatic pumps have an integral control circuit and two float switches operated at low voltages.

The automatic pumps are indicated by the symbol, A, added to the series name in the model code.

They are available in all sizes of the series.



Automatic Alternation pumps

Tsurumi also offers Automatic Alternation pumps for dual automatic operations using two pumps at a time. Just combine an ordinary automatic pump (2 floats) to an automatic alternation pump (3 floats). This enables the two pumps to operate alternately without control panel.

The automatic alternation pumps are identified by the symbol, W, added to the series name in the model code. They are available in the same output ranges as those of the ordinary automatic models.

How the Auto-alternation Type Works

- Operation is enabled by merely connecting the power supply.

Primary Operation

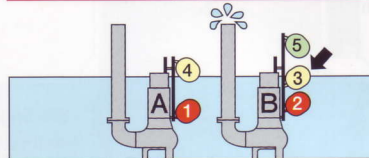

- 1 Float 3 operates, and pump B starts to discharge water.

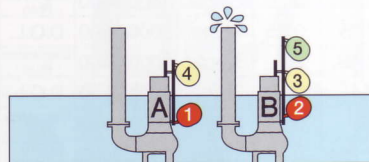

- 2 Water is discharged (water level falls).

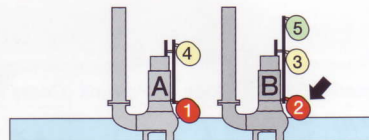

- 3 Stop float 2 of pump B operates to end water discharge. At this time, alternation start float 3 of pump B rests for one discharge operation.

Secondary Operation

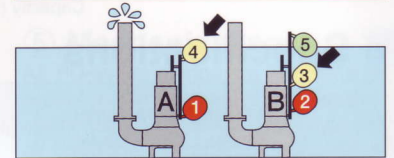

- 1 Start float 4 of pump A operates to start water discharge. The pump ends primary operation, and stops operating.

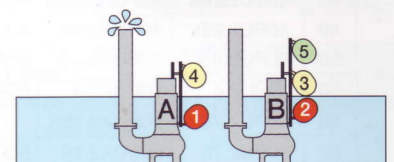

- 2 Water is discharged (water level falls).

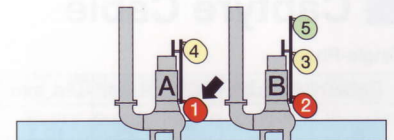

- 3 Stop float 1 of pump A operates to end water discharge. At the same time, start float 3 of pump B becomes ready for operation.

※Primary operation and secondary operation are repeated alternately.

※Both primary and secondary operations are performed simultaneously when water has risen to an abnormal level.

The specifications and designs here in may be changed for improvement without notice.

TSURUMI
MANUFACTURING CO.,LTD.

Your Dealer



APPENDIX B

The programme of the tentative installation schedule and commissioning period



APPENDIX C

Systemic Drawing of Monitoring System



APPENDIX D

Calibration Procedure

6.6 Calibration

Measuring chain calibration is performed in this function group.

The calibration data are saved in an EEPROM directly in the sensor. For this reason:

- Recalibration is not required in the event of a power failure
- Recalibration is not required when the transmitter is replaced
- Customer-specific recalibration is required, however, when the sensor is replaced

Three calibration data records are saved in the sensor for each of the four main operating modes.

	FNU/NTU	ppm or mg/l	g/l	%
Factory data record no. 1 not changeable	Formazine	SiO ₂	Activated sludge	Residual concrete water
User data record no. 2 changeable	Formazine	Kaolin	Activated sludge	Residual concrete water
User data record no. 3 changeable	Formazine	SiO ₂	Activated sludge	Residual concrete water

Select the desired data record in the SETUP 2 function group in the B4 field.

- In the FNU operating mode, the sensor is factory calibrated with formazine traceable to ISO 7027.
- In the ppm operating mode, the calibration data records for Kaolin and SiO₂ are derived from the FNU data records.
- In the % operating mode, the calibration data records are set to the average of various residual concrete waters. They are preset in such a way that correct values are displayed for average clarity. However the settings do not follow a standard currently applicable.
- In the g/l operating mode also, the sensor is not calibrated to a fixed value as no standard is directly applicable. You must carry out a calibration because the media of the various applications differ too greatly here.

Three-point sensor calibration is the standard calibration. It is absolutely **essential**:

- When commissioning the sensor in sludge applications
- When changing to another sludge type

Three-point sensor calibration is **not** necessary:

- When commissioning the sensor in the drinking water area (sensor has been calibrated for drinking water applications in the factory).
- For residual concrete water. Density measurement for determining the concentration of residual concrete water is based on %-data records. They are preset in such a way that correct values are displayed for average clarity. One-point calibration is often sufficient to adjust the system in the event of deviating values.
- When recalibrating with the same sludge type. One-point calibration suffices here if the degrees of lightness and clarity, for example, do not differ too greatly.



Note!

- Sludge samples tend to sediment. Mix the sample well, even during the calibration process, but not to the extent that gas bubbles are formed.
- The sensor has to be far enough away from the floor and the wall of the calibration vessel during calibration. The immersion depth must be at least 40 mm.
- The characteristic determined during the calibration is stored in the selected data record (Setup 2, B4 field).
- Calibration is not possible if data record 1 is selected with the factory setting.
- If the calibration data deviate from the standard values by a factor of two or more, a warning (E084) is output. The calibration results are accepted.
- If the calibration results are outside the permitted range, a calibration error (E045) is indicated. The calibration results are not accepted.
- For every type of calibration, the installation adjustment and the offset are reset to zero and the slope to 1.0.

Calibration menu

The calibration menu offers the following options:

3-Pt	Three-point calibration
Corr	Three-point correction
Edit	Edit calibration
Refl	Installation adjustment
1-Pt	One-point calibration
Data	Calibration data

Three-point calibration (3-Pt)

You should perform the calibration in the turbidity/solids concentration range in which you plan to measure. The overall calibration characteristic of the measuring chain is determined using three samples of known turbidity or known solids content.

Calibration with a very dark, high-absorption medium returns small slopes while light, clear media return big slopes.

You can create the requisite probes by diluting a medium sample. In general, very good calibration results are achieved with a concentration gradation of 10 %, 33 % and 100 %. The following condition must be met for the calibration:

Sample A > 1.1 x sample B > 1.1 x sample C

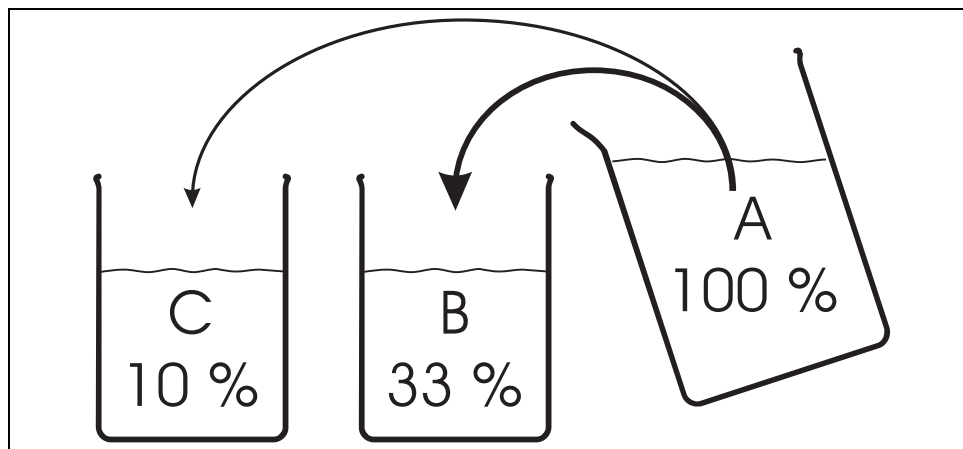

Fig. 35: Making the samples for a three-point calibration

- A Original sample
- B 1 part sample A + 2 parts water
- C 1 part sample A + 9 parts water

A different dilution ratio should be selected for very high-absorption media to achieve accurate calibration results. Instead of 100 % – 33 % – 10 %, you can use dilution ratios of 100 % – 20 % – 5 % or 100% – 10 % – 3.3 %.

If the scattered light of a light sample hits a sensor that is calibrated for a dark medium, it can happen that the signal value is so high that it is above the calibration curve.

Three-point correction (Corr)

If the calibration was performed with an unknown sample concentration but with a defined dilution, the correct value determined afterwards in the laboratory is entered here.

Edit calibration (Edit)

If each of the samples has been determined afterwards in the laboratory, the correction for the calibration is entered here.

Installation adjustment (Refl)

In installation adjustment, backscatter from the immediate sensor environment is compensated. Installation adjustment must be performed with a medium whose turbidity is lower than 2 FNU or 5 ppm.

One-point calibration (1-Pt)

In the area of TS/concentration measurement, one-point calibration is used to change the conversion factor (field C166). The slopes are not changed.

In the FNU range, the two slope values are adjusted by a one-point calibration. This is possible because the conversion factor in the FNU range is always 1 and the editing range is limited to 4000 FNU. In this way, the two curves are always increasing and the calibration remains clear.

In the ppm range, the slope values are adjusted up to 500 ppm. For higher values, the conversion factor is changed.

Calibration data (Data)

Here, you can display the calibration points 1 to 3, slope 1 and 2 and the conversion factor.

With three-point calibration, the curves used in the algorithm are adjusted as precisely as possible using the data points acquired. The difference between the ideal curve of the algorithm and the three actual calibration points can be found as a correction factor in the C161, C162 and C163 fields of the data function. The correction values are indicated in %. The values should be as close to 100 % as possible. Values from 70 to 80 % are acceptable. 50 % in one or two calibration points clearly indicates a problematic calibration. A warning (E084) is output here for this reason. This can mean that significant deviations can occur between the calibration points. The calibration points themselves are always retrieved correctly.

Version TB: Initial settings for residual concrete water

The version TB contains the Plus-package with additional setting options. The default values set in individual fields of the menus differ from the standard version to make commissioning as simple as possible.

These values are so selected that no additional settings need to be made for applications in **residual concrete water**. If you ever reset the device to the original factory settings (set default), you can find valid values for residual concrete water in the table below.

	Menu field	Setting
Mode of operation	A1	spec.
Unit	A2	kg/l
Display format	A3	XX.xx
Measured value damping	A5	10
Calibration data record	B4	3
Current output	O1	Out1
Characteristic	O2	lin
Current range	O211	0 to 20 mA
Measured value 0 mA	O212	1.00
Measured value 20 mA	O213	1.30
Active characteristic	K1	1
Edited characteristic	K2	1
Table option	K3	edit
Number of value pairs	K4	2
Support point	K5	1 to 2
Measured value / display value	K6 / K7	1: 0%/1.00 2: 50%/1.50
Language version	S1	GER

**Note!**

Calibration is carried out in the % measuring range (the transmitter switches automatically). With the above setting, a density of e.g. 1.12 kg/l = 12 % must be selected. In some cases, it may be necessary to adapt the calibration to a real sample. To do so, perform a single-point calibration.

Coding		Field	Selection or range (factory settings bold)	Display	Info
C		Function group CALIBRATION			Calibration settings.
	C1 (1)	Select calibration	3-Pt = Three-point calibration (1) Corr = Three-point correction (2) Edit = Edit calibration (3) Refl = Fitting with reflection compensation (4) 1-Pt = Single-point calibration (5) Data = Calibration data (6)		For data set 1 (B4), only the "Data" function is accessible. The offset is reset with 3 Pt and Edit.
Immerse sensor in the calibration solution (sample 1).					Immerse the sensor so that there is sufficient distance to the tank wall (no reflection).
		C111	Enter concentration of the first calibration solution Value from last calibration		
Immerse sensor in the calibration solution (sample 2).					Immerse the sensor so that there is sufficient distance to the tank wall (no reflection).
		C112	Enter concentration of the second calibration solution Value from last calibration		C112 ≥ 1.1 x C111
Immerse sensor in the calibration solution (sample 3).					Immerse the sensor so that there is sufficient distance to the tank wall (no reflection).
		C113	Enter concentration of the third calibration solution Value from last calibration		C113 ≥ 1.1 x C112
		C114	Calibration status is displayed o. k. E. xxx		

Coding		Field	Selection or range (factory settings bold)	Display	Info
	C115	Store calibration results	yes no new		If C114 = E xxx, then only no or new (Exception: calibration warning E84). If new, return to C. If yes / no, return to "Measurement".
C1 (2)		Select calibration	3-Pt = Three-point calibration (1) Corr = Three-point correction (2) Edit = Edit calibration (3) Refl = Fitting with reflection compensation (4) 1-Pt = Single-point calibration (5) Data = Calibration data (6)		
	C121	Enter correct concentration of the third calibration solution	Current value from C113 entire measuring range		If the calibration is performed with an unknown sample concentration, but with a definite dilution (1/10; 1/3;1), the laboratory value is to be entered.
	C122	Calibration status is displayed	o. k. Exxx		
	C123	Store calibration results	yes no new		If C122 = E xxx, then only no or new (Exception: calibration warning E84). If new, return to C. If yes / no, return to "Measurement".
C1 (3)		Select calibration	3-Pt = Three-point calibration (1) Corr = Three-point correction (2) Edit = Edit calibration (3) Refl = Fitting with reflection compensation (4) 1-Pt = Single-point calibration (5) Data = Calibration data (6)		
	C131	Enter concentration of the first calibration solution	Current value from C111 entire measuring range		
	C132	Enter concentration of the second calibration solution	Current value from C112 C132 ≥ 1.1 x C131		
	C133	Enter concentration of the third calibration solution	Current value from C113 C133 ≥ 1.1 x C132		

Coding		Field	Selection or range (factory settings bold)	Display	Info	
		C134	Calibration status is displayed	o.k. Exxx		
		C135	Store calibration results?	yes no new		If C134 = E xxx, then only no or new (Exception: calibration warning E84). If new, return to C. If yes / no, return to "Measurement".
	C1 (4)	Select calibration	3-Pt = Three-point calibration (1) Corr = Three-point correction (2) Edit = Edit calibration (3) Refl = Fitting with reflection compensation (4) 1-Pt = Single-point calibration (5) Data = Calibration data (6)		Only for solutions = 2 FNU / 5 ppm! Backscatter from the immediate sensor environment is compensated for clear media.	
		C141	Enter correct measured value	0.0 NTU 0.0 to 2.0 NTU 0.0 FNU 0.0 to 2.0 FNU 0.0 ppm 0.0 to 5.0 ppm 0.0 mg/l 0.0 to 5.0 mg/l		Only for the ranges NTU, FNU, ppm, mg/l
		C142	Calibration status is displayed	o.k. Exxx		
		C143	Store calibration results?	yes no new		If C142 = E xxx, then only no or new (Exception: calibration warning E84). If new, return to C. If yes / no, return to "Measurement".
	C1 (5)	Select calibration	3-Pt = Three-point calibration (1) Corr = Three-point correction (2) Edit = Edit calibration (3) Refl = Fitting with reflection compensation (4) 1-Pt = Single-point calibration (5) Data = Calibration data (6)		For FNU: Adaption C164, C165 For ppm, mg/l: up to 500 - adaption C164, C165 above 500 - adaption C166 For g/l, %: Adaption C166. An existing basic calibration (three-point) is corrected by the single-point calibration.	
		C151	Enter current calibration value	Current measured value Entire measuring range		

Coding		Field	Selection or range (factory settings bold)	Display	Info
	C152	Calibration status is displayed	o.k. Exxx	The display shows 'CAL READY' and 'HOLD' at the top. Below is a small bar chart icon, followed by 'o.k.' and 'C152' on the same line. The word 'Status' is displayed on the line below.	
	C153	Store calibration results?	yes no new	The display shows 'CAL READY' and 'HOLD' at the top. Below is a small bar chart icon, followed by 'yes' and 'C153' on the same line. The word 'Store' is displayed on the line below.	If C152 = E xxx, then only no or new (Exception: calibration warning E84). If new, return to C. If yes / no, return to "Measurement".
C1 (6)		Select calibration	3-Pt = Three-point calibration (1) Corr = Three-point correction (2) Edit = Edit calibration (3) Refl = Fitting with reflection compensation (4) 1-Pt = Single-point calibration (5) Data = Calibration data (6)	The display shows 'CAL' and 'HOLD' at the top. Below is a small bar chart icon, followed by 'Data' and 'C1' on the same line. The word 'Calibrat' is displayed on the line below.	
	C161	Calibration point 1 is displayed	Comparison value	The display shows 'CAL' and 'HOLD' at the top. Below is a small bar chart icon, followed by '101.4%' and 'C161' on the same line. The word 'Concentr1' is displayed on the line below.	Deviation relative to standard sensor (= 100 %)
	C162	Calibration point 2 is displayed	Comparison value	The display shows 'CAL' and 'HOLD' at the top. Below is a small bar chart icon, followed by '99.3%' and 'C162' on the same line. The word 'Concentr2' is displayed on the line below.	Deviation relative to standard sensor (= 100 %)
	C163	Calibration point 3 is displayed	Comparison value	The display shows 'CAL' and 'HOLD' at the top. Below is a small bar chart icon, followed by '98.7%' and 'C163' on the same line. The word 'Concentr3' is displayed on the line below.	Deviation relative to standard sensor (= 100 %)
	C164	Slope 1 is displayed	Current value	The display shows 'CAL' and 'HOLD' at the top. Below is a small bar chart icon, followed by '230' and 'C164' on the same line. The word 'Slope 1' is displayed on the line below.	Slope of characteristic 1 of the sensor
	C165	Slope 2 is displayed	Current value	The display shows 'CAL' and 'HOLD' at the top. Below is a small bar chart icon, followed by '375' and 'C165' on the same line. The word 'Slope 2' is displayed on the line below.	Slope of characteristic 2 of the sensor
	C166	Conversion factor is displayed	Current value	The display shows 'CAL' and 'HOLD' at the top. Below is a small bar chart icon, followed by '1' and 'C166' on the same line. The word 'ConvFact' is displayed on the line below.	Conversion factor of internal turbidity units into displayed unit

6.7 Offset

The settings in the OFFSET function group can be used to calibrate the measurement to a reference measurement. This requires a linear shift of all the measured values, i.e. the adjustment is determined for one measured value, and all others are calculated using the same adjustment.

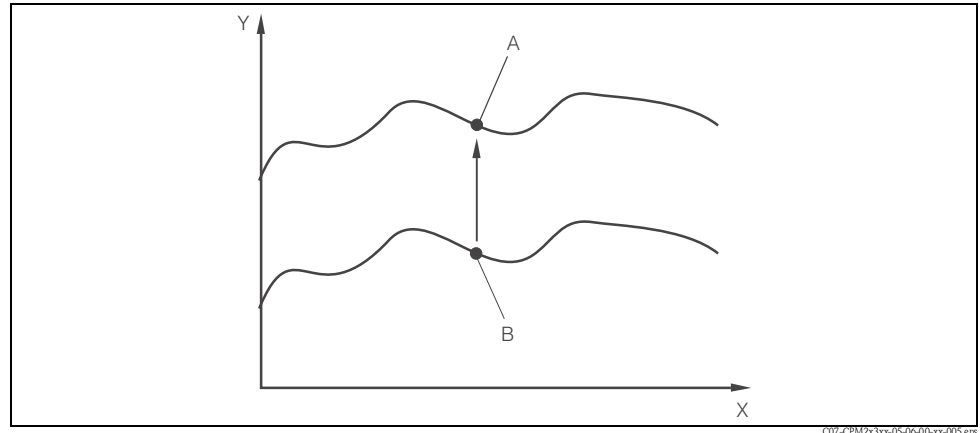

Fig. 36: Offset

X Time
Y Measured value
A Calibrated value
B Current measured value



Note!
 Following a calibration, the offset is automatically set to zero.

Coding	Field	Setting range (Factory settings, bold)	Display	Info
V	Function group OFFSET			
V1	Enter absolute value	Current measured value		
V2	Enter offset	Current offset		
V3	Calibration status is displayed	o.k. E xxx		
V4	Store calibration result?	yes no new		If V3 = E xxx, then only no or new . If new, return to V. If yes/no, return to "Measurement".

6.8 Slope

With the settings in the function group SLOPE, a measured value can be adapted to a reference value. All measured values are proportionally adapted over the entire measuring range according to this change.

Example:

The displayed measured value is 2.5 g/l. It is adapted to the reference value of 2.0 g/l by means of the slope function. The change is 20 %, i.e. all measured values are reduced by 20 % over the entire measuring range.



Note!

An OFFSET having been edited before is reset to the factory setting. In contrast to the one-point calibration, the edited slope can be reset by setting the slope factor to 1.0.

Coding	Field	Setting range (Factory settings, bold)	Display	Info
N	Function group SLOPE			
N1	Enter absolute value	Current measured value		
N2	Enter slope	Current slope		Slope is displayed, can be edited.
N3	Status is displayed	o.k. E xxx		
N4	Store slope?	yes no new		

Appendix H – Installation of Silt Screen at Cooling Water Intake No. 9



Installation of silt screen at cooling water intake (Windsor House)

**Appendix I – Proposal on Impact Monitoring for Odour
Patrol along the Shorelines of Causeway Bay Typhoon
Shelter and Ex-Wan Chai Public Cargo Working Area**



Lam Geotechnics Limited

Contract No. HK/2009/05
Wanchai Development Phase II and Central-Wanchai Bypass
Sampling, Field Measurement and testing Works (Stage 1)
Proposal on Impact Monitoring for Odour Patrol
along the shorelines of CBTS and ex-PCWA

CONTRACT NO: HK/2009/05

**WANCHAI DEVELOPMENT PHASE II AND CENTRAL
WANCHAI BYPASS
SAMPLING, FIELD MEASUREMENT AND TESTING WORK
(STAGE 1)**

**PROPOSAL ON IMPACT MONITORING FOR ODOUR PATROL
ALONG THE SHORELINES OF CAUSEWAY BAY TYPHOON
SHELTER AND EX-WAN CHAI PUBLIC CARGO WORKING
AREA**

CLIENTS:

**Civil Engineering and Development
Department**

and

Highways Department

PREPARED BY:

Lam Geotechnics Limited

11/F Centre Point
181-185 Gloucester Road,
Wanchai, H.K.

Telephone: (852) 2882-3939
Facsimile: (852) 2882-3331
E-mail: info@lamenviro.com
Website: <http://www.lamenviro.com>

CERTIFIED BY:

Raymond Dai
Environmental Team Leader

DATE:

13 June 2011

Ref.: AACWBIECEM00_0_1530L.11

6 July 2011

Lam Geotechnics Limited
11/F Centre Point
181-185 Gloucester Road
Wan Chai, Hong Kong

By Post and Fax (2882 3331)

Attention: Mr. Raymond Dai

Dear Sir,

**Re: Contract No. HK/2009/05
Wan Chai Development Phase II and Central-Wan Chai Bypass –
Sampling, Field Measurement and Testing Works (Stage 1)
Proposal on Impact Monitoring for Odour Patrol along the Shorelines of
Causeway Bay Typhoon Shelter and Ex-Wan Chai Public Cargo Working
Area**

Reference is made to your submission of the captioned submission dated 13 June 2011 for our review and comment.

Please be informed that we have no adverse comments on the captioned submission.

Thank you for your kind attention.

Yours sincerely,



David Yeung
Independent Environmental Checker

c.c.	HyD	Mr. Jones Lai	by fax: 2714 5289
	CEDD	Mr. Patrick Keung	by fax: 2577 5040
	AECOM	Ms. Gloria Tang	by fax: 2587 1877

Q:\Projects\AACWBIECEM00\Corr\AACWBIECEM00_0_1530L.11.doc



TABLE OF CONTENTS

1. INTRODUCTION.....	1
2. IMPACT MONITORING FOR ODOUR PATROL.....	1
3. MONITORING FREQUENCY	2
4. COMPLIANCE CHECKING.....	2

LIST OF TABLES

<i>Table 4.1</i>	<i>Action and Limit Levels for Odour Patrol</i>
<i>Table 4.2</i>	<i>Event / Action Plan for Odour Patrol</i>

LIST OF FIGURES

<i>Figure 2.1</i>	<i>Location Plan for Water Quality Monitoring Stations</i>
-------------------	--

LIST OF APPENDICES

<i>Appendix 2.1</i>	<i>Certificate for a Qualified Odour Panel Member</i>
<i>Appendix 2.2</i>	<i>A sample of Field Data Record Sheet</i>

1. INTRODUCTION

- 1.1.1. The objective of the odour patrol is to capture any potential worst odour level and monitor the odour intensity along the shorelines of Causeway Bay Typhoon Shelter (CBTS) and ex-Wan Chai Public Cargo Working Area (ex-PCWA) when there is temporary reclamation in Causeway Bay Typhoon Shelter and/or in the ex-Wan Chai Public Cargo Working Area, or when there is dredging of the odorous sediment and slime at the south-western corner of the Causeway Bay Typhoon Shelter during July, August and September.
- 1.1.2. The odour patrol shall be carried to identify the odour intensity in the impact monitoring. It is a judgement by observers patrolling and sniffing around to detect any odour in the vicinity of the CBTS and ex-PCWA.
- 1.1.3. The proposal is presented the methodology of the odour patrol, monitoring frequency and compliance checking as per Section 2.8 of the Updated EM&A Manual under EP-356/2009.

2. IMPACT MONITORING FOR ODOUR PATROL

- 2.1.1. The odour patrol shall be conducted by an independent trained personnel / competent persons patrolling and sniffing at the identified seven locations, namely OP1-OP7 along the shore as shown in **Figure 2.1** to detect any odour at the concerned hours (afternoon is preferred for higher daily temperature). The patrol sequence shall be generally started from less odorous locations to stronger odorous locations along the route. The independent trained personnel / competent persons shall be fulfilled the following requirements. A certificate for a qualified odour panel member is enclosed in **Appendix 2.1** for reference. Certificate for the n-butanol screening test is valid for 3 months from the issued date.
 - be at least 16 years of age;
 - be free from any respiratory illnesses; and
 - not be allowed to smoke, eat, drink (except water) or use chewing gum or sweets 30 min before and during odour patrol;
- 2.1.2. The qualified person will use the nose (olfactory sensor) to sniff odours at different locations. The main odour emission sources and the areas to be affected by the odour nuisance shall be identified.
- 2.1.3. During the odour patrol, the findings including odour intensity, odour nature and possible odour sources, and also the local wind speed and direction at each location shall be recorded. The instant weather conditions should be measured and recorded using a portable environment anemometer (Lutron LM-8000 or equivalent) for references. A sample of field data record sheet is enclosed in **Appendix 2.2**. In addition, some relevant meteorological such as daily average temperature, and daily average humidity, on that surveyed day will be obtained from the Hong Kong Observatory Weather Stations at Hong Kong Park and Hong Kong Observatory for references. The tidal data will be referred to the Quarry Bay Station for reference.

2.1.4. The perceived odour intensity is to be divided into 5 levels which are ranked in the descending order as follows:

- 0 - Not detected. No odour perceived or an odour so weak that it cannot be easily characterised or described;
- 1 - Slight Identifiable odour, and slight chance to have odour nuisance;
- 2 - Moderate Identifiable odour, and moderate chance to have odour nuisance;
- 3 - Strong Identifiable, likely to have odour nuisance;
- 4 - Extreme Severe odour, and unacceptable odour level.

3. MONITORING FREQUENCY

3.1. When there is temporary reclamation in Causeway Bay Typhoon Shelter and/or in the ex-Wan Chai Public Cargo Working Area, or when there is dredging of the odorous sediment and slime at the south-western corner of the Causeway Bay Typhoon Shelter, the odour patrol shall be carried out bi-weekly intervals during July, August and September to detect any odour at the concerned hours (afternoon is preferred for higher daily temperature).

4. COMPLIANCE CHECKING

4.1. The findings including odour intensity, odour nature and possible odour sources, and also the local wind speed and direction at each location will be recorded. In addition, some relevant meteorological and tidal data such as daily average temperature, and daily average humidity, on that surveyed day will be obtained from the Hong Kong Observatory Station for reference. The Action and Limit levels for odour patrol are shown in **Table 4.1**.

Table 4.1 Action and Limit Levels for Odour Patrol

Parameters	Action	Limit
Odour Nuisance (from odour intensity analysis or odour patrol)	<ul style="list-style-type: none"> • When two documented complaint are received; or • Odour Intensity of 2 is measured from odour intensity analysis. 	<ul style="list-style-type: none"> • Five or more consecutive genuine documented complaints within a week; or • Odour Intensity of 3 or above is measured from odour intensity analysis.

4.2. Should non-compliance of the air quality criteria occur, actions in accordance with the Action Plan in **Tables 4.2** shall be carried out.

Table 4.2 Event / Action Plan for Odour Patrol

Event	ACTION	
	Person-in-charge of Odour Monitoring	Implementation Agent Identified by CEDD
ACTION LEVEL		
Exceedance of Action Level	<ol style="list-style-type: none"> 1. Identify source/reason of exceedance; 2. Repeat odour patrol to confirm finding. 	<ol style="list-style-type: none"> 1. Carry out investigation to identify the source/reason of exceedance; 2. Rectify any unacceptable practice 3. Implement more mitigation measures if necessary; 4. Inform EPD or MD if exceedance is



Event	ACTION	
	Person-in-charge of Odour Monitoring	Implementation Agent Identified by CEDD
		considered to be caused by expedient connections or floating debris.
LIMIT LEVEL		
Exceedance of Limit Level	<ol style="list-style-type: none">1. Identify source / reason of exceedance;2. Repeat odour patrol to confirm findings;3. Increase odour patrol frequency;4. If exceedance stops, cease additional odour patrol.	<ol style="list-style-type: none">1. Carry out investigation to identify the source/reason of exceedance. Investigation shall be completed within 2 weeks;2. Rectify any unacceptable practice;3. Formulate remedial actions;4. Ensure remedial actions properly implemented;5. If exceedance continues, consider what more/enhanced mitigation measures shall be implemented;6. Inform EPD or MD if exceedance is considered to be caused by expedient connections or floating debris.



Figure 2.1

Layout Plan for Odour Patrol Locations

C6 AND C7: EXISTING SEAWATER INTAKE

 : ODOR PATROL ROUTES FOR CONSTRUCTION PHASE

 : MONITORING STATION FOR DO MEASUREMENT FOR CONSTRUCTION PHASE

 Odour Patrol Location

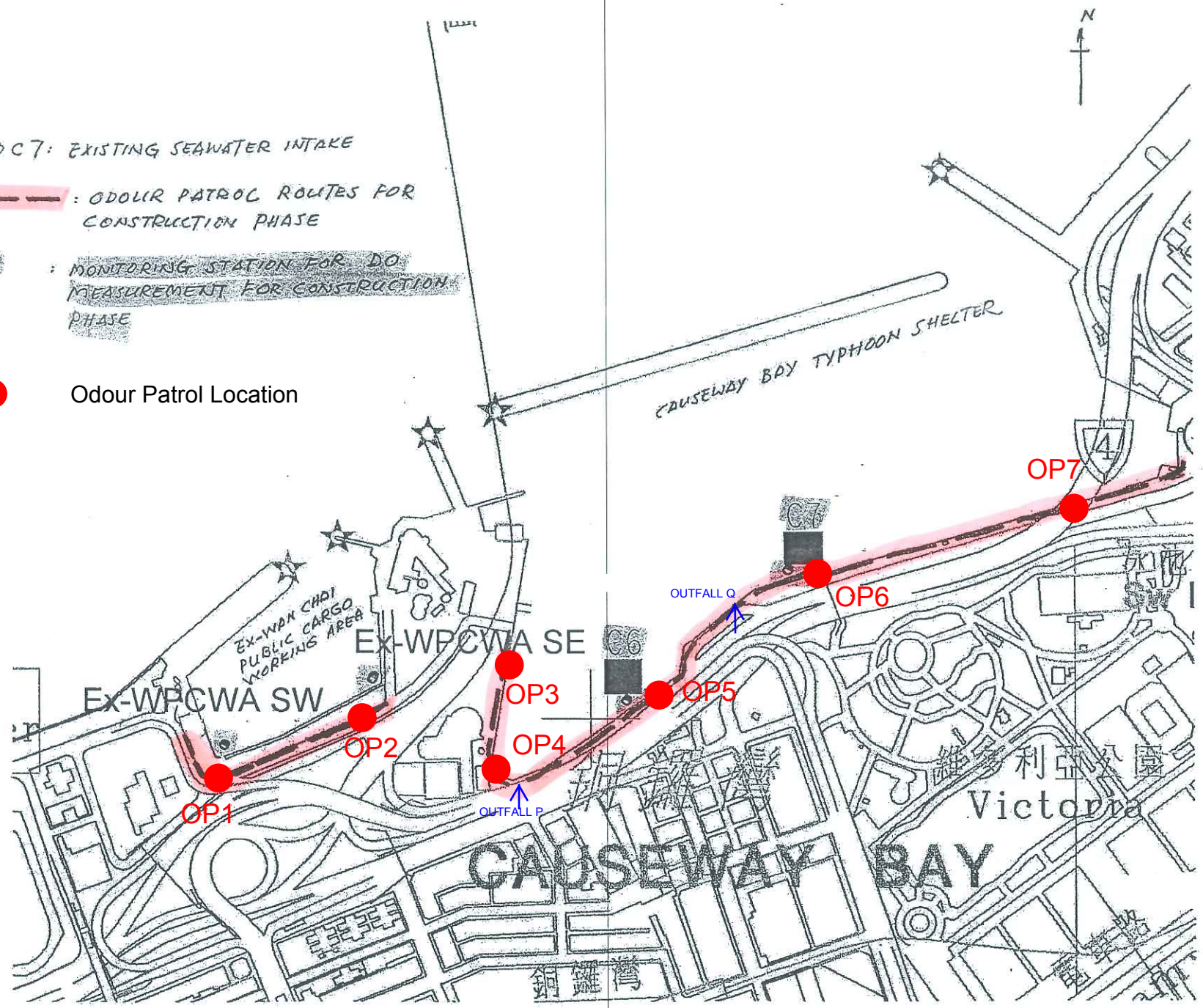



Lam Geotechnics Limited

Contract No. HK/2009/05
Wanchai Development Phase II and Central-Wanchai Bypass
Sampling, Field Measurement and testing Works (Stage 1)
Proposal on Impact Monitoring for Odour Patrol
along the shorelines of CBTS and ex-PCWA

Appendix 2.1

Certificate for a Qualified Odour Panel Member

Certificate for a Qualified Odour Panel Member



Odour Research Laboratory
 The Hong Kong Polytechnic University,
 Hung Hom, Kowloon, Hong Kong
 Tel: (852) 2766 6016 Fax: (852) 2334 6389

09 June 2011

Re: A Certificate for a Qualified Odour Panel Member

This is to certify that Mr. Ng Kin-hung participated in a set of n-butanol screening tests in our laboratory between Oct 2010 – Apr 2011 and his odour threshold of n-butanol in nitrogen gas was found to be in the range of 20 – 80 ppb/v. According to the requirement of the European Standard Method of Air Quality – Determination of Odour Concentration by Dynamic Olfactometry (EN13725), he is qualified to participate olfactometry analysis to determine odour concentration. The relevant data are shown as follows:

Ng Kin Hung	y_{ITE}	$10^{-y_{ITE}}$	S_{ITE}	$10^{-S_{ITE}}$	unit	20 Oct. 2010	17 Nov. 2010	8 Dec. 2010	22 Dec. 2010	21 Feb. 2011	9 Mar. 2011	18 Mar. 2011	3 Apr. 2011	14 Apr. 2011	20 Apr. 2011
		50.8			dilution	1334.4	932.6	704.8	932.6	1334.4	932.6	932.6	1334.4	932.6	932.6
					$\mu\text{mol} / \text{mol}$	37.9	54.3	71.8	54.3	37.9	54.3	54.3	37.9	54.3	54.3
	1.6961		0.0963	1.25	$\log_{10}(\mu\text{mol} / \text{mol})$	1.5789	1.7345	1.8561	1.7345	1.5789	1.7345	1.7345	1.5789	1.7345	1.7345

Yours sincerely

Li Xiangzhi

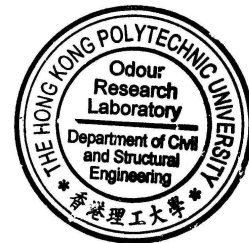

Professor X. Z. Li
 Odour Research Laboratory at PolyU



Lam Geotechnics Limited

Contract No. HK/2009/05
Wanchai Development Phase II and Central-Wanchai Bypass
Sampling, Field Measurement and testing Works (Stage 1)
Proposal on Impact Monitoring for Odour Patrol
along the shorelines of CBTS and ex-PCWA

Appendix 2.2

A sample of Field Data Record Sheet

